

E



JAY R. SMITH MFG. CO.®
 MEMBER OF MORRIS GROUP INTERNATIONAL
 POST OFFICE BOX 3237
 MONTGOMERY, ALABAMA 36109-0237 (USA)
 TEL: 334-277-8520 FAX: 334-272-7396 www.jrsmith.com



MEMBER OF:

LOCATION

DRAWING NUMBER
SDX4890SIZE
ASCALE:
NONEDATE:
2-5-65APPROVED BY:
JMCHECKED BY:
JSDRAWN BY:
DA

DX4890

FIGURE
NUMBERWE CAN ASSUME NO RESPONSIBILITY FOR USE OF SUPERSEDED OR VOID DATA
DIMENSIONS ARE SUBJECT TO MANUFACTURERS TOLERANCE AND CHANGE WITHOUT NOTICE

FLOOR ACCESS COVERS

ROUND DECK PLUG WITH THREADED SPANNER WRENCH COVER

FUNCTION: Used as floor cleanout. Threaded machine fit cover is watertight and requires special spanner wrench for removal. Large flange provides bearing surface for traffic deck applied coating.

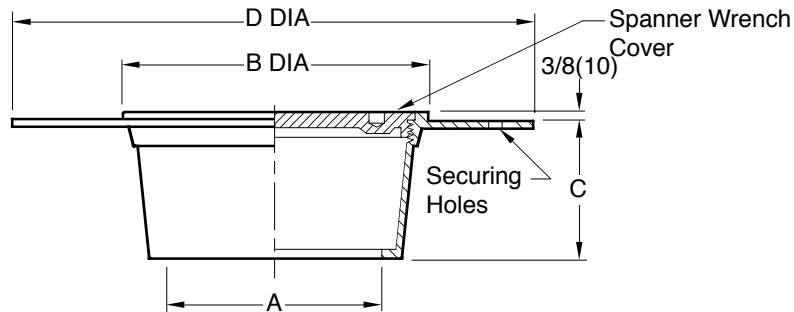

Fig. DX4890C INSIDE CAULK

A SIZE	B DIA	C	D DIA
02 (50)	4 (100)	1 5/8 (41)	12 (305)
03 (75)	4 3/4 (120)	2 1/2 (64)	12 3/4 (325)
04 (100)	6 (150)	2 1/2 (64)	13 3/4 (350)

NOTE: If water-proof deck covering is greater (or less) than the dimension shown, the cleanout body should be set to compensate for the variation in thickness.

REGULARLY FURNISHED:
All Nickel Bronze with Polished Scoriated Cover

VARIATIONS:

Spanner Wrench -SW
 Securing Holes -SH

OPTIONAL MATERIALS:

Polished Bronze -PB

Note: Spanner Wrench must be ordered separately

NOTE: Dimensions shown in parentheses are in millimeters.

REV.	DATE	DESCRIPTION	BY	CKD. BY	WEIGHT POUNDS	VOLUME CUBIC FEET	FIGURE NUMBER DX4890
E	1-23-96	Added Millimeters	EMB	BS			
D	7-27-94	Revised	EMB	BS			
C	8-16-93	Submittal Update	TWK	BS			
B	2-18-83	Revised and Redrawn	CR	BS/JM			



WARNING: Cancer and Reproductive Harm - www.P65Warnings.ca.gov