

F

SMITH® JAY R. SMITH MFG. CO.®
 MEMBER OF MORRIS GROUP INTERNATIONAL
 POST OFFICE BOX 3237
 MONTGOMERY, ALABAMA 36109-0237 (USA)
 TEL: 334-277-8520 FAX: 888-377-7818 www.jrsmith.com



MEMBER OF:



LOCATION

FLOOR DRAINS STAINLESS STEEL - CARBON STEEL

12" (305) ROUND TOP - HEAVY DUTY DRAIN WITH TRACTOR GRATE

FUNCTION: Used in heavy traffic areas. Large deep body provides reservoir where heavy flow is expected, and where a corrosion resistant drain is required.

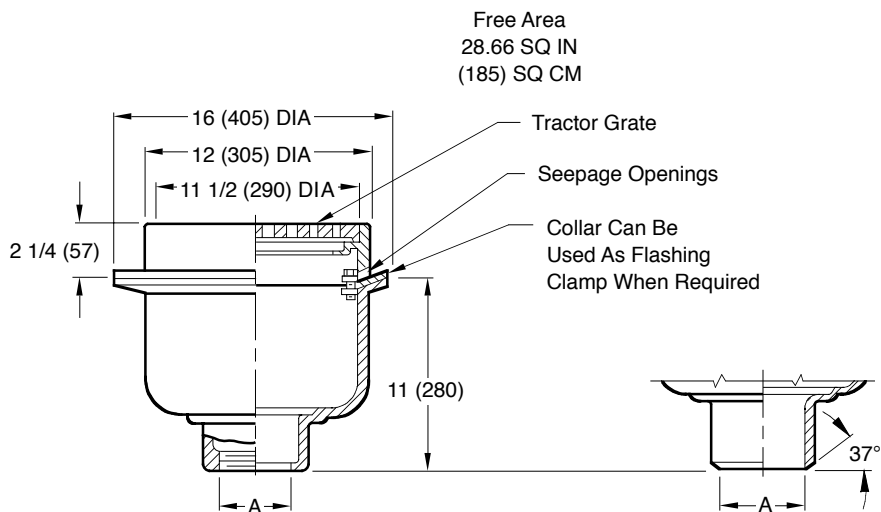

A (Pipe Size) = 03(75), 04(100), 05(125) or 06(150)

- Fig. 9734C CAULK OUTLET
 Fig. 9734T THREADED OUTLET
 Fig. 9734Y NO-HUB OUTLET

Butt Weld Outlet

Schedule 40 Regularly Furnished

REGULARLY FURNISHED:

CF8 (Equivalent to Type 304) Rough Finish Stainless Steel Body, Flashing Collar with Seepage Openings and Rough Bronze Tractor Grate.

VARIATIONS:

- 4(100) or 6"(150) Dia. Funnel (Specify Fig. 9703)
 8 3/4(220) x 3 3/4"(95) Funnel (Specify Fig. 9704)
 Satin Finish Top -SF
 Sediment Bucket -B
 Vandal Proof Grate -U
 90° Side Outlet (Specify Fig. 9759)
 BW Butt Weld Outlet (Specify Schedule -S05, -S10, -S40)

OPTIONAL MATERIALS:

- A-27 Carbon Steel -A27
 Cast Iron Grate -CIG
 CF8M (Equivalent to Type 316) Stainless Steel -316
 CF8 (Rough) Stainless Steel Grate -RG
 Ductile Iron Grate -M
 Nickel Bronze Top -NB
 Polished Bronze Top -PB

Design Pressures and Temperatures

1. With proper outlet connection, shall be watertight up to 10 ft. of water column (4.34 psig).
2. When exposed to effluent appropriate for drain material, the drain shall withstand effluent temperatures of 180 degrees F at ambient pressure.

NOTE: Dimensions shown in parentheses are in millimeters.

DRAWING NUMBER
S973SIZE
ASCALE:
NONEDATE:
11-12-84APPROVED BY:
TDCHECKED BY:
VGDDRAWN BY:
PJ

9734

FIGURE NUMBER

WE CAN ASSUME NO RESPONSIBILITY FOR USE OF SUPERSEDED OR VOID DATA

DIMENSIONS ARE SUBJECT TO MANUFACTURERS TOLERANCE AND CHANGE WITHOUT NOTICE

F E D C	2-16-22 10-18-11 4-28-06 04/24/00	Added NO-HUB Outlet option Added Note Revised Variations Changed Metric Equivalents	KK TBW RN JJ	CL CL CL BS	WEIGHT POUNDS	VOLUME CUBIC FEET	FIGURE NUMBER 9734
REV.	DATE	DESCRIPTION	BY	CKD. BY			



WARNING: Cancer and Reproductive Harm - www.P65Warnings.ca.gov