



**JAY R. SMITH MFG. CO.**  
 MEMBER OF MORRIS GROUP INTERNATIONAL  
 POST OFFICE BOX 3237  
 MONTGOMERY, ALABAMA 36109-0237 (USA)  
 TEL: 334-277-8520 FAX: 334-272-7396 www.jrsmith.com



LOCATION

# FLOOR DRAINS STAINLESS STEEL - CARBON STEEL

## 8 1/2" (215) ROUND MEDIUM DUTY TOP WITH EXTENDED INTEGRAL FLANGE FOR WELDING TO STEEL DECKS

**FUNCTION:** Used in areas where drain body is welded to deck or where waterproof traffic floor coverings are applied, and where a corrosion resistant drain is required.

Free Area  
 20.50 SQ IN  
 (132) SQ CM

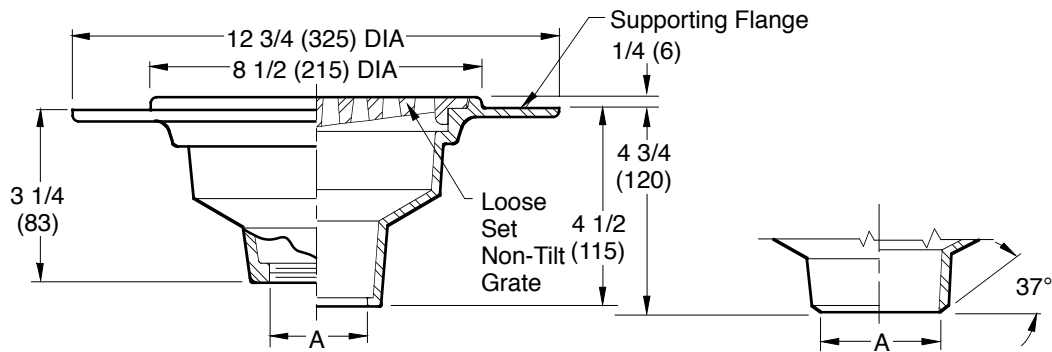

A (Pipe Size) = 02(50), 03(75) or 04(100)

Butt Weld Outlet  
 Schedule 40 Regularly Furnished

- Fig. 9705C . . . . . CAULK OUTLET
- Fig. 9705T . . . . . THREADED OUTLET

**REGULARLY FURNISHED:**

CF8 (Equivalent to Type 304)  
 Rough Finish Stainless Steel  
 Body and Loose Set Non-Tilt  
 Grate.

**VARIATIONS:**

- 4(100) or 6"(150) Dia. Funnel (Specify Fig. 9703)
- 8 3/4(220) x 3 3/4"(95) Funnel (Specify Fig. 9704)
- Satin Finished Top -SF
- Sediment Bucket -B
- Solid Scoriated Cover -SC
- Vandal Proof Grate -U
- For 90° Outlet (Specify Fig. 9759)
- BW Butt Weld Outlet (Specify Schedule -S05, -S10 or -S40)

**OPTIONAL MATERIALS:**

- A-27 Carbon Steel -A27
- Cast Iron Grate -CIG
- CF8M (Equivalent to Type 316) Stainless Steel -316
- Nickel Bronze Grate -NB
- Polished Bronze Grate -PB

**Design Pressures and Temperatures**

1. With proper outlet connection, shall be watertight up to 10 ft. of water column (4.34 psig).
2. When exposed to effluent appropriate for drain material, the drain shall withstand effluent temperatures of 180 degrees F at ambient pressure.

**NOTE:** Dimensions shown in parentheses are in millimeters.

DRAWING NUMBER: S9705  
 SIZE: A  
 SCALE: NONE  
 DATE: 11-12-84  
 APPROVED BY: TD  
 CHECKED BY: VGD  
 DRAWN BY: P.J.  
 FIGURE NUMBER: 9705  
 DIMENSIONS ARE SUBJECT TO MANUFACTURERS TOLERANCE AND CHANGE WITHOUT NOTICE

E	10-18-11	Added Note	TBW	CL	WEIGHT POUNDS	VOLUME CUBIC FEET	FIGURE NUMBER <b>9705</b>
D	4-28-06	Revised Variations	RN	CL			
C	04/24/00	Changed Metric Equivalents	JJ	BS			
B	12-13-95	Added Millimeters	EMB	BS			
REV.	DATE	DESCRIPTION	BY	CKD. BY			