

FIGURE NUMBER **9678-100**

DIMENSIONS ARE SUBJECT TO MANUFACTURERS TOLERANCE AND CHANGE WITHOUT NOTICE

DRAWING NUMBER **SSQ-9678-100**

DATE: **5-27-2020**

APPROVED BY: **PACE**

CHECKED BY: **PACE**

DRAWN BY: **MW**

SCALE: **NONE**

SIZE **A**

WE CAN ASSUME NO RESPONSIBILITY FOR USE OF SUPERSEDED OR VOID DATA

STAINLESS STEEL THRESHOLD DRAIN

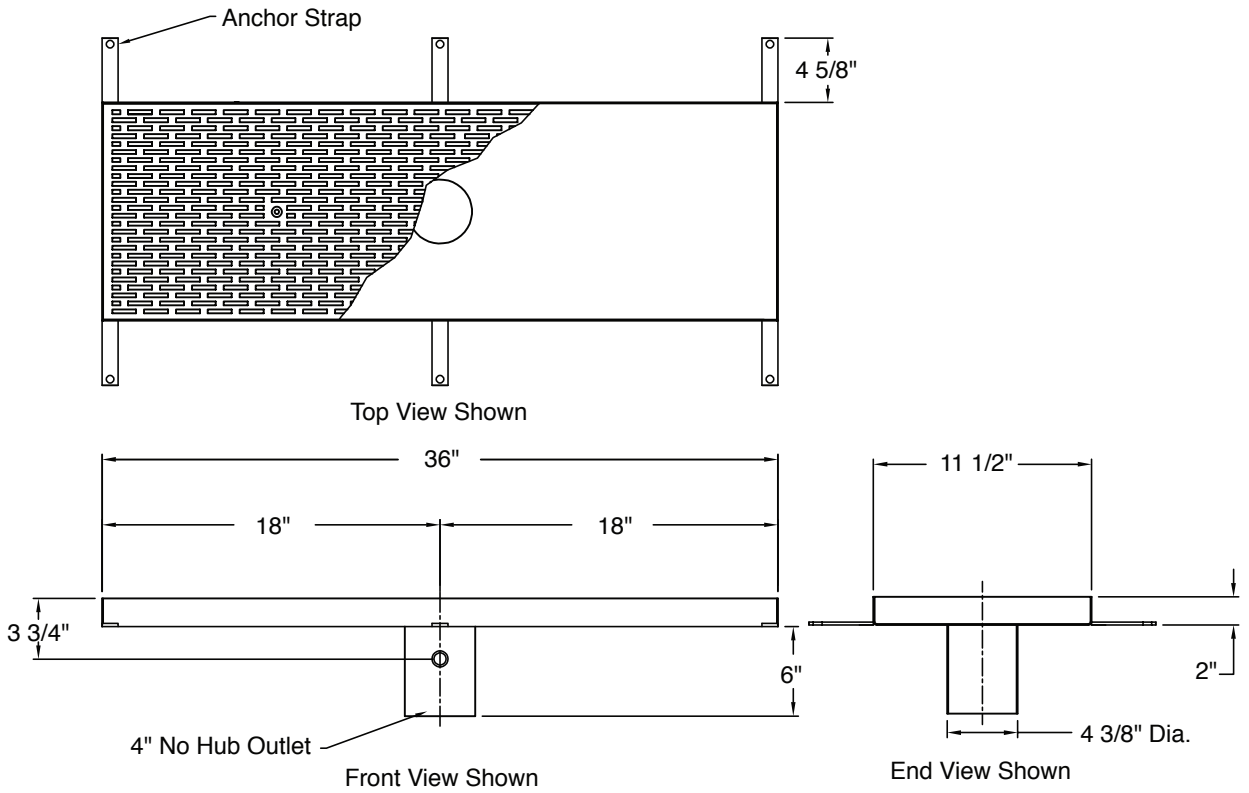

REGULARLY FURNISHED:

Custom threshold/lobby trench drain, 11 1/2" wide, 2" deep, all fabricated of 14 gage stainless steel conforming to ASTM A-240 (type 304). Drain provided with 4" no hub vertical outlet, 6 anchor straps and vandal proof stainless steel longitudinal heel-proof ADA slotted grate with open area of 46.30 sq in. per linear foot and with 1/4" wide slots that is certified to flow 100 GPM flow rate.

OPTIONS:

- Less Anchor Straps -LAS
- Bronze Painted Finish on Grates -BPPG
- Inside Black Finish -BPF
- 6" No Hub Vertical Outlet
- Black Powder Coated Interior
- DX Flange -DX
- Additional Anchor Straps
- Specify Outlet Position
- Anchor Straps 12 Req'd -AS
- 1/2" NPT Trap Primer Connection -TP

Complies with 2013 California Building Code 403.6.1, 403.6.2, 3007.4, 3008.4
 Complies with 2013 San Francisco Fire Code, Section 511.1.4

REV.	DATE	DESCRIPTION	BY	CKD. BY
A	8-18-21	Updated Reg. Furnished	KK	PJ

WEIGHT POUNDS	VOLUME CUBIC FEET
---------------	-------------------

FIGURE NUMBER
9678-100