

SMITH® JAY R. SMITH MFG. CO.®
 MEMBER OF MORRIS GROUP INTERNATIONAL
 POST OFFICE BOX 3237
 MONTGOMERY, ALABAMA 36109-0237 (USA)
 TEL: 334-277-8520 FAX: 334-272-7396 www.jrsmith.com



MEMBER OF:

LOCATION

WE CAN ASSUME NO RESPONSIBILITY FOR USE OF SUPERSEDED OR VOID DATA

DRAWING NUMBER
9649

SIZE
A

SCALE:
NONE

DATE:
2-27-15

APPROVED BY:
SJM

CHECKED BY:
JM

DRAWN BY:
TBW

STAINLESS STEEL CLEANOUT

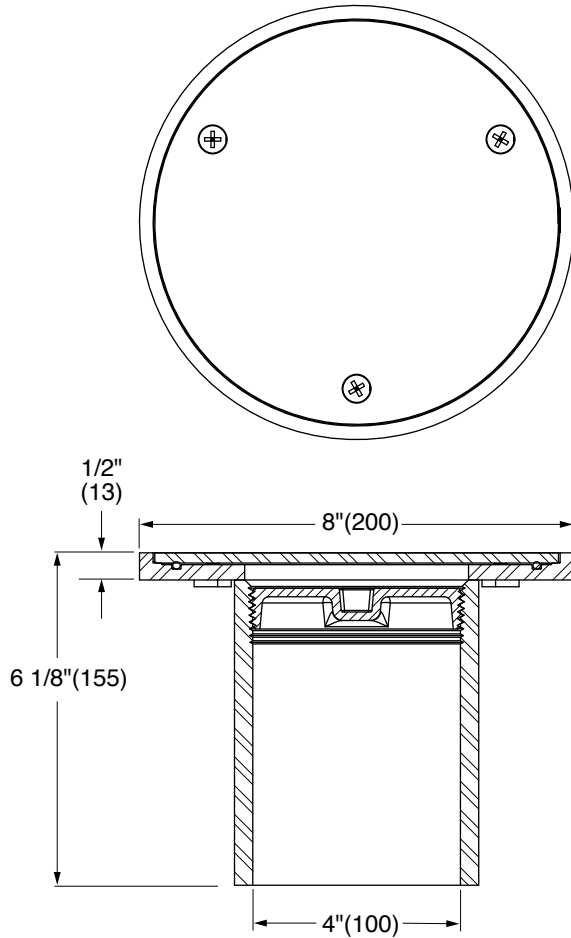

**Special Duty Load Rated
per ASME A112.6.3**

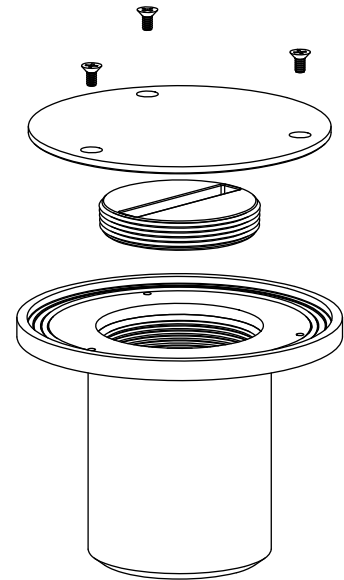

USDA ACCEPTED

REGULARLY FURNISHED:

Fabricated Type 304 Stainless Steel Cleanout with O-Ring, Sealed Secured Cover and Slotted Closure Plug with 4"(100) Spigot Connection.

VARIATIONS:

- NO-HUB Outlet -Y
- SCH 5 BW -S05
- SCH 10 BW -S10
- SCH 40 BW -S40
- USDA Compliant

OPTIONAL MATERIALS:

- Type 316 Stainless Steel -316

9649

FIGURE NUMBER

REV.	DATE	DESCRIPTION	BY	CKD. BY	WEIGHT POUNDS	VOLUME CUBIC FEET	FIGURE NUMBER
C	6-1-18	Added ASME Note	TBW	CL			9649
B	5-17-18	Revised Variations, Added Note	TBW	CL			
A	6-8-17	Rev. Reg. Furn., Variations	TBW	JM			