

F

SMITH® JAY R. SMITH MFG. CO.®
 MEMBER OF MORRIS GROUP INTERNATIONAL
 POST OFFICE BOX 3237
 MONTGOMERY, ALABAMA 36109-0237 (USA)
 TEL: 334-277-8520 FAX: 334-272-7396 www.jrsmith.com



LOCATION

OIL INTERCEPTORS

ALL STEEL OIL INTERCEPTORS

FUNCTION: Large capacity oil interceptors are used in large garages, service areas and industrial plants where waste laden with oil and sediment must be intercepted. The intercepted oils are drawn off by gravity to a storage tank or container. Any sediment which is included in the discharge is collected in a large sediment bucket and periodically removed.

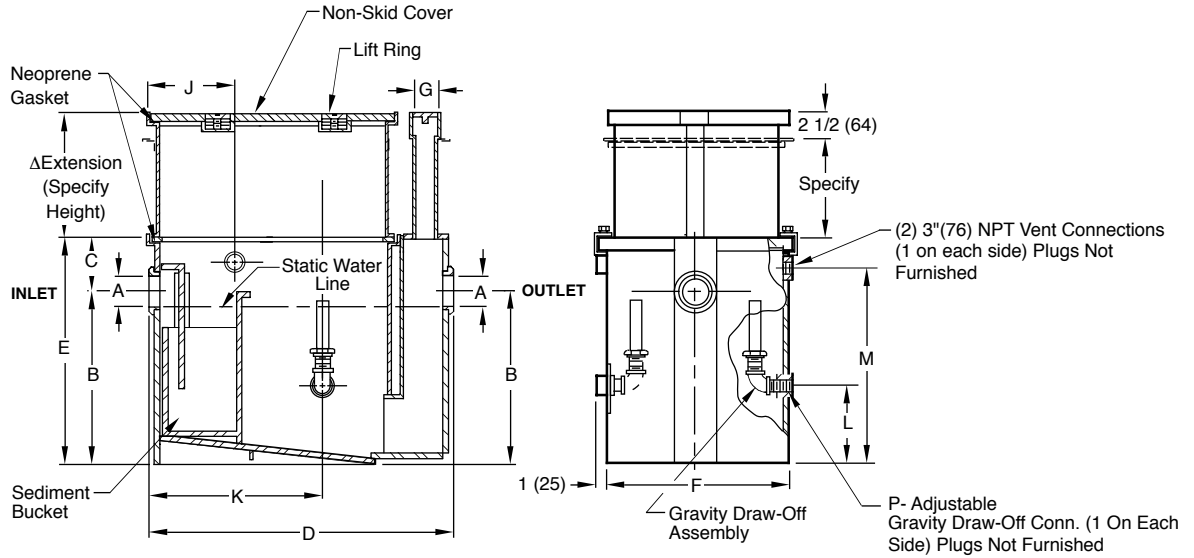

NOTE: Interceptor shall be vented on outlet side per local code requirements.

PCN/ Fig. No.	GPM Flow Rate	Inlet and Outlet Size	Dimensions						C.O. Plug Size	Dimensions					Draw- Off
			Roughing Dimensions			Body				G	J	K	L	M	
			A*	B	C	D	Height E	Width F							
8560 (-E)	75	04(100)	21 1/2(545)	15 1/2(395)	50 3/4(1290)	37(940)	30 1/2(775)	3(76)	21(535)	28 1/4(720)	13(330)	32 3/4(830)	2(51)		
8565 (-E)	100	04(100)	27(685)	16 1/2(420)	54 3/4(1390)	43 1/2(1105)	33 1/2(850)	3(76)	23(585)	30 1/4(770)	18 1/2(470)	39 1/4(995)	2(51)		
8570 (-E)	150	05(125)	33(840)	17 1/2(445)	60 3/4(1543)	50 1/2(1283)	38 1/2(980)	4(100)	25 1/2(650)	34 1/4(870)	23 1/2(595)	46 1/4(1175)	2 1/2(64)		
8575 (-E)	200	05(125)	37(940)	17 1/2(445)	67 3/4(1720)	54 1/2(1385)	43 1/2(1105)	4(100)	29(735)	38 1/4(970)	27 1/2(700)	50 1/4(1275)	2 1/2(64)		
8580 (-E)	250	05(125)	40(1015)	18(455)	73 3/4(1875)	58(1473)	47 1/2(1205)	4(100)	32(815)	42 1/4(1075)	30 1/2(775)	53 3/4(1365)	2 1/2(64)		
8585 (-E)	350	05(125)	43 1/2(1105)	18(455)	85 3/4(2178)	61 1/2(1562)	54 1/2(1385)	4(100)	38(965)	50 1/4(1275)	34(865)	57 1/4(1455)	2 1/2(64)		
8590 (-E)	500	06(150)	48(1220)	18(455)	103 1/4(2623)	66(1615)	64 1/2(1640)	5(125)	46(1170)	62 1/4(1580)	38(965)	61 3/4(1570)	2 1/2(64)		

*Available with larger inlet and outlet when specified.
 Δ Extension Regularly Furnished integrally.

REGULARLY FURNISHED:
 Steel Interceptor and Extension with Gray Duco Coating Inside and Outside and Flow Control Fitting.

- VARIATIONS:**
- Anchor Flange -F
 - Flange and Flashing Clamp -F-C
 - NO-HUB Adaptor (4) Req'd (Specify Fig. 2646Y)
 - Traffic Rated Cover-H20

- OPTIONAL MATERIALS:**
- Acid Resistant Coating Inside - ARI
 - Acid Resistant Coating Outside - ARO
 - Acid Resistant Coating Inside and Outside - ARIO
 - Aluminum Cover -AC

NOTE: Dimensions shown in parentheses are in millimeters.

DRAWING NUMBER
8560 (-E)

SIZE
A

SCALE:
NONE

DATE:
11-14-89

APPROVED BY:
CR

CHECKED BY:
TD

DRAWN BY:
EMB

8560 (-E)

FIGURE NUMBER

F	12-3-13	Revised Drawing	TBW	CL	WEIGHT POUNDS	VOLUME CUBIC FEET	FIGURE NUMBER 8560 (-E)
E	5-5-06	Revised Drawing & Note	RN	CL			
D	2-3-05	Revised Variations	RN	CL			
C	11-17-03	Added Δ To Notes	RN	CL			
REV.	DATE	DESCRIPTION	BY	CKD. BY			

WE CAN ASSUME NO RESPONSIBILITY FOR USE OF SUPERSEDED OR VOID DATA

DIMENSIONS ARE SUBJECT TO MANUFACTURERS TOLERANCE AND CHANGE WITHOUT NOTICE