

H

SMITH® JAY R. SMITH MFG. CO.®
 MEMBER OF MORRIS GROUP INTERNATIONAL
 POST OFFICE BOX 3237
 MONTGOMERY, ALABAMA 36109-0237 (USA)
 TEL: 334-277-8520 FAX: 334-272-7396 www.jrsmith.com



LOCATION

DRAWING NUMBER
8510-CAN

SIZE
A

SCALE:
NONE

DATE:
4-19-96

APPROVED BY:

CHECKED BY:

DRAWN BY:
CMD

8510-CAN

FIGURE NUMBER

WE CAN ASSUME NO RESPONSIBILITY FOR USE OF SUPERSEDED OR VOID DATA

DIMENSIONS ARE SUBJECT TO MANUFACTURERS TOLERANCE AND CHANGE WITHOUT NOTICE

OIL INTERCEPTORS

FUNCTION: Used in service stations, parking garages, and industrial plants where discharged water contains oil and sediment. Interceptor collects oil and conveniently permits the collected oil to be drained to a storage tank by means of an adjustable gravity draw-off connection. Sediment and chips are collected in sediment bucket and should be periodically removed. Interceptors should not be located directly in traffic areas. If required, specify extra heavy duty traffic cover.

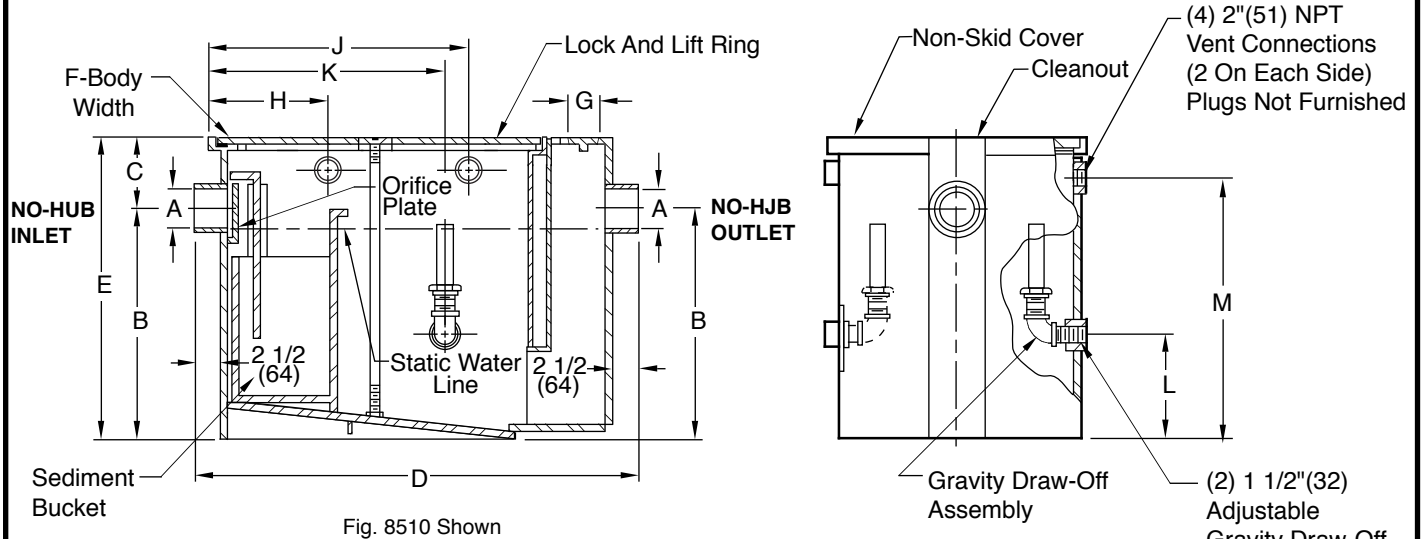

Fig. 8510 Shown

NOTE: Interceptor shall be vented on outlet side per local code requirements.

NOTE: It is the responsibility of the installer to check all parts (internal and external) to verify they are in their proper operating order and location.

NOTE: 2"(51) must be added to dimension D and F when extension is specified for clearance of extension clamps.

PCN/ Fig. No.	GPM Flow Rate	Inlet and Outlet Size	Dimensions								C.O. Plug Size	Dimensions				
			Roughing Dimensions				Body		G	H		J	K	L	M	
			A*	B	C	D	Height	Width								F
8510	10	02(50)	9 1/2(240)	3 3/4(95)	21 1/4(540)	13 1/4(335)	11 1/2(290)	2(51)	5 1/4(135)	12(305)	12(305)	4(100)	9 3/4(250)			
8515	15	02(50)	12(305)	3 1/2(89)	25(635)	15 1/2(395)	13 1/2(345)	2(51)	6 1/4(160)	13 3/4(350)	14 1/4(360)	5 3/4(145)	12(305)			
8520	20	03(80)	13(330)	4(100)	28 1/2(725)	17(430)	15 3/4(400)	2(51)	7(180)	16(405)	16 1/2(420)	4 1/2(115)	13 1/2(345)			
8525	25	03(80)	15 1/4(390)	4 1/2(115)	30(760)	19 3/4(500)	16 3/4(425)	2(51)	6 1/4(160)	18(455)	18 3/4(475)	6 1/4(160)	16 1/4(415)			
8535	35	04(100)	16(405)	5(125)	32 1/2(825)	21(535)	18 1/4(465)	2(51)	7(180)	20(510)	21 1/4(540)	7(180)	17 1/2(445)			
8550	50	04(100)	17 1/2(445)	6 3/4(170)	35 1/2(900)	24 1/4(615)	20 3/4(525)	2(51)	7(180)	23(585)	22(560)	7 1/2(190)	20 3/4(525)			

*Available with larger inlet and outlet when specified.

REGULARLY FURNISHED:

Steel Interceptor with Gray Duco Coating Inside and Outside and Internal Flow Control Orifice Plate.

2"(51) min. extension available. Anchor flange & flashing clamp not available on less than 4"(100) extension.

NOTE: Dimensions shown in parentheses are in millimeters.

VARIATIONS:

- Anchor Flange -F (Flange available with extension only)
- Traffic Rated Cover -H20
- Flashing Flange and Clamp -F-C
- Steel Extension -E (Specify Height eg: -E12 For 12"(305) Ext)

H	1-27-14	Revised Note & Variations Revised Drawing Revised Drawing & Note Revised Table, Dimension	TBW	SJM	WEIGHT POUNDS	VOLUME CUBIC FEET	FIGURE NUMBER 8510-CAN
G	12-3-13		TBW	CL			
F	5-8-06		RN	CL			
E	12-8-05		RN	CL			
REV.	DATE	DESCRIPTION	BY	CKD. BY			