

DRAWING NUMBER
s7141

SIZE
A

SCALE:
NONE

DATE:
10/1/06

APPROVED BY:
CEL

CHECKED BY:
CL

DRAWN BY:
RN

WE CAN ASSUME NO RESPONSIBILITY FOR USE OF SUPERSEDED OR VOID DATA

SENTINEL ALARM SYSTEM

FUNCTION: The Sentinel Alarm System is designed to be installed in an existing floor cleanout closure plug to notify the building maintenance staff/home owner whenever there is a backup condition detected in the sewer line. The backup may occur due to a drainage system blockage, the system's inability to handle peak flow during a storm surge or backflow from the street sewer. The Sentinel Alarm System is activated by a pressure increase in the vertical portion of the sewer cleanout tee due to a backup condition.

APPLICATION REQUIREMENTS:
 The top of the horizontal sewer line **MUST** be 7"(180) below the top of the cleanout plug where the Sentinel Alarm is to be installed.

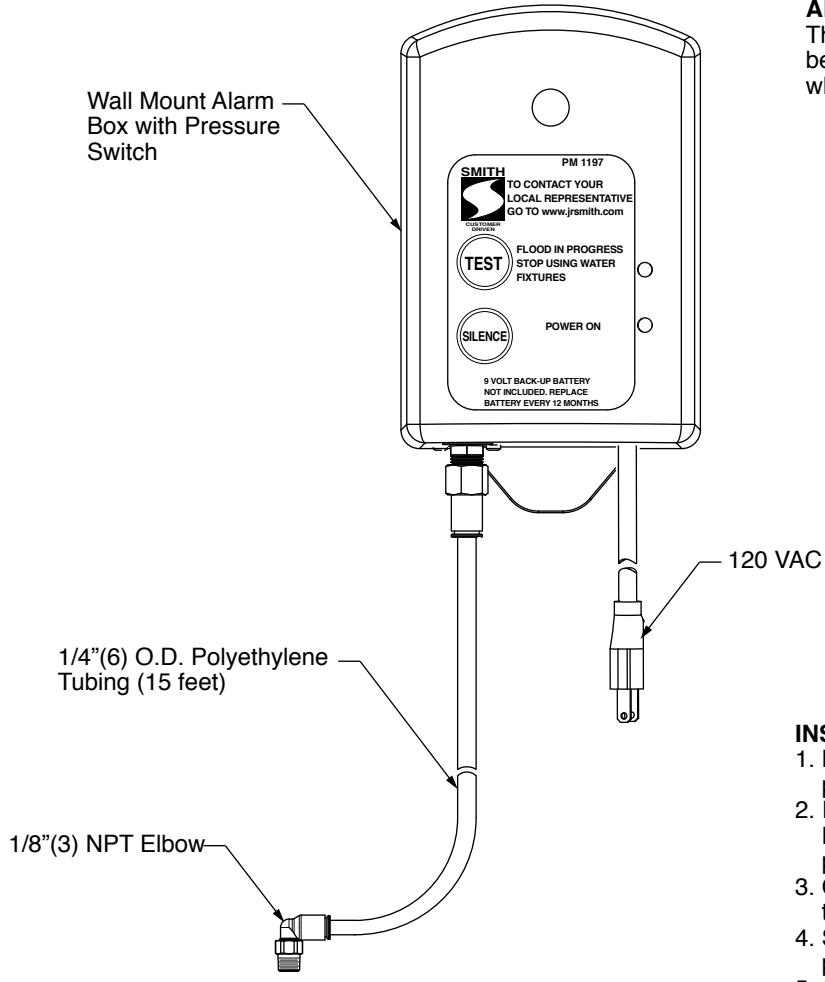

Fig. 7141

- INSTALLATION STEPS:**
1. Locate floor cleanout, remove the closure plug and drill and tap for 1/8 NPT connection.
 2. Install the supplied elbow fitting into the 1/8"(3) NPT tapped connection in the cleanout closure plug.
 3. Connect the elbow and the polyethylene tubing by inserting the tubing into the elbow.
 4. Secure the alarm box to the wall and plug in power cord to a 120 VAC wall receptacle.
 5. Connect the polyethylene tubing to the fitting in the bottom of the alarm box.

REGULARLY FURNISHED:
 Wall Mount Alarm Box with Pressure Switch,
 15 Feet of 1/4"(6) O.D. Polyethylene Tubing
 and 1/8"(3) NPT Elbow.

NOTE: For proper operation, all connections between the tubing, fittings and cleanout closure plug **MUST** be airtight.

See reverse side for installation illustration.

NOTE: Dimensions shown in parentheses are in millimeters.

7141

REV.	DATE	DESCRIPTION	BY	CKD. BY	WEIGHT POUNDS	VOLUME CUBIC FEET	FIGURE NUMBER
C	5-10-07	Revised Text.	JJ	CL			7141
B	3-30-07	Revised Text.	JJ	CL			
A	3-6-07	Revised Dwg.	RN	CL			

SENTINEL ALARM SYSTEM

INSTALLATION ILLUSTRATION

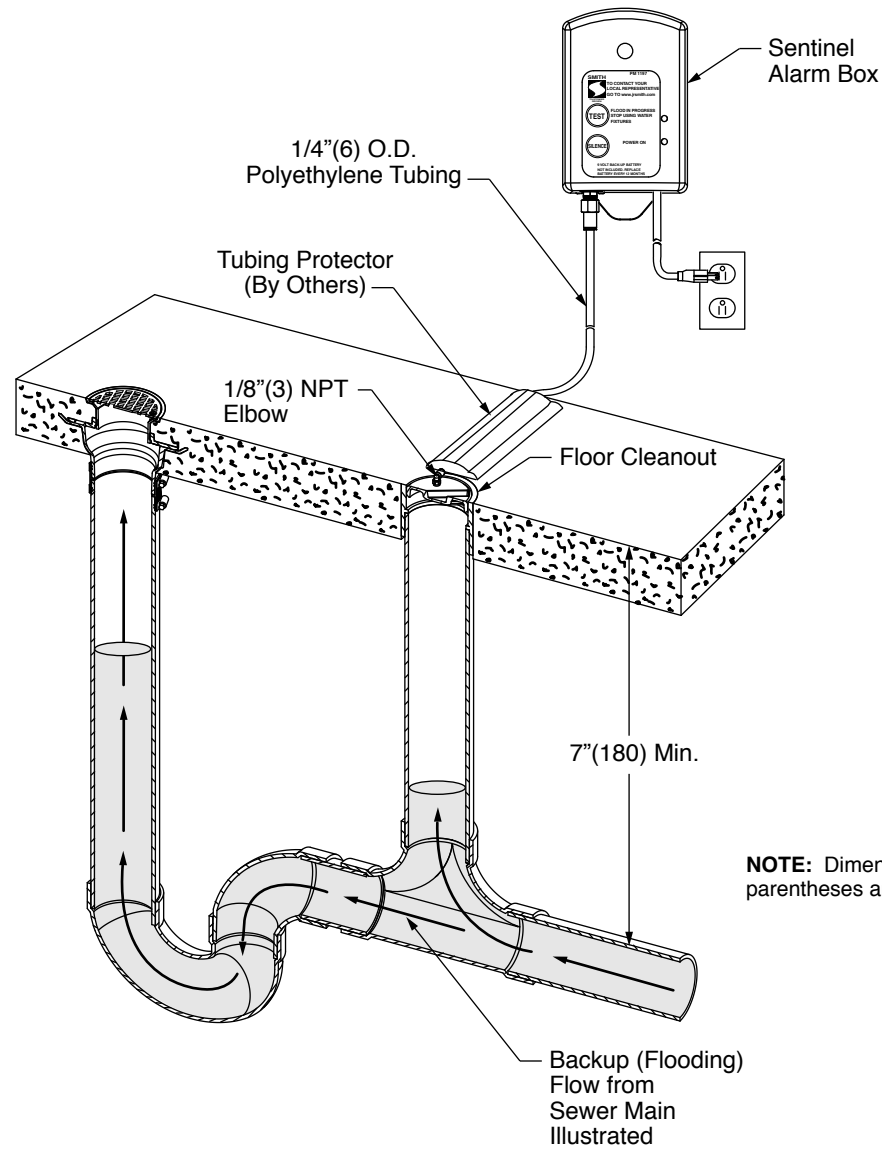

NOTE: Dimensions shown in parentheses are in millimeters.

HOW IT WORKS: A pressure switch is incorporated into the alarm box. When the sewer backs up to a level of 5" (125) - 6" (150) above the horizontal drain line, the pressure switch closes the 9V circuit sounding the alarm and activating a red light. The alarm will continue to sound until the silence button is pressed. The red light will remain on for as long as the sewer has back pressure warning that the fixtures should not be used. When the red light goes off, the main sewer has returned to normal and use of the plumbing fixtures may resume. The switch resets automatically to be ready to detect the next backup condition. The alarm operates on 120 VAC or 9V battery (not Included); when powered by 120 VAC, the battery acts as backup.

DRAWING NUMBER: 7141BS
 SIZE: A
 SCALE: NONE
 DATE: 10/1/06
 APPROVED BY: CEL
 CHECKED BY: CL
 DRAWN BY: RN
 FIGURE NUMBER: 7141BS

WE CAN ASSUME NO RESPONSIBILITY FOR USE OF SUPERSEDED OR VOID DATA

C B A	5-10-07 3-30-07 3-6-07	Revised Text. Revised Text. Revised Dwg.	JJ JJ RN	CL CL CL	WEIGHT POUNDS	VOLUME CUBIC FEET	FIGURE NUMBER 7141BS
REV.	DATE	DESCRIPTION	BY	CKD. BY			