

GUARDIAN PLUS DUAL CHECK
1/4 TURN NON-FREEZE HYDRANT WITH AUTOMATIC DRAINING INTEGRAL VACUUM BREAKER, INTEGRAL SERVICE SHUT-OFF VALVE AND DUAL CHECK VALVE

FUNCTION: For installation in interior or exterior walls where an exposed hose connection is acceptable. It provides positive non-freeze protection and integral water service shut-off valve. Adaptable to all types of wall construction.

1/4 Turn of the Key Allows Full Flow to be Obtained
Meets ASME A112.21.3M
Complies with ASSE 1019-B, 1052 & 1053
IAPMO Listed - File # 2749

NOTES:

1. Recommended wall opening 2 1/4(57) x 4 3/4(121).
2. When ordering specify wall thickness in 1(25) increments as follows 4,5,6 24.
3. All Jay R. Smith hydrants are manufactured with "NO LEAD" brazing rings and USDA approved lubricants.
4. When wall clamp -WC is specified increase the wall thickness dimension by 2(51).
5. Add 3/4 (19) to overall length when -IC1 is specified..
6. When specifying the -SAP mild climate the wall thickness shall be 2(51).
7. Dimensions shown in parentheses are in millimeters.
8. The AB1953, California Lead Law, and NSF/ANSI Standard 61-2008 - Drinking Water Systems Components are not applicable to Jay R. Smith hydrants as they do not convey/dispense water for human consumption through drinking or cooking.
9. An additional inlet isolation or shut-off valve is usually not needed with this hydrant, but if required it should be mounted (10) feet or more from the hydrant inlet.
10. Temperature Range: 33.0°F to 140.0°F (0.6°C to 60.0°C).
11. This ASSE 1019 device shall not be subjected to more than twelve (12) hours of continuous water pressure.
12. **FOR IRRIGATION PURPOSES ONLY.**

Seepage of a small amount of water may occur from the vacuum breaker upon initial opening and closing of the hydrant. This is normal operation.

Installer is responsible for providing a 100% watertight positive seal at the hydrant to wall interface. Seal all the flange with an appropriate sealant recommended by a sealant manufacturer. NOTE: Jay R. Smith does not warrant the performance or life expectancy of the sealant material.

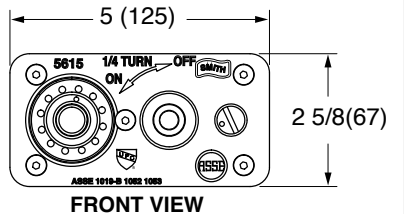
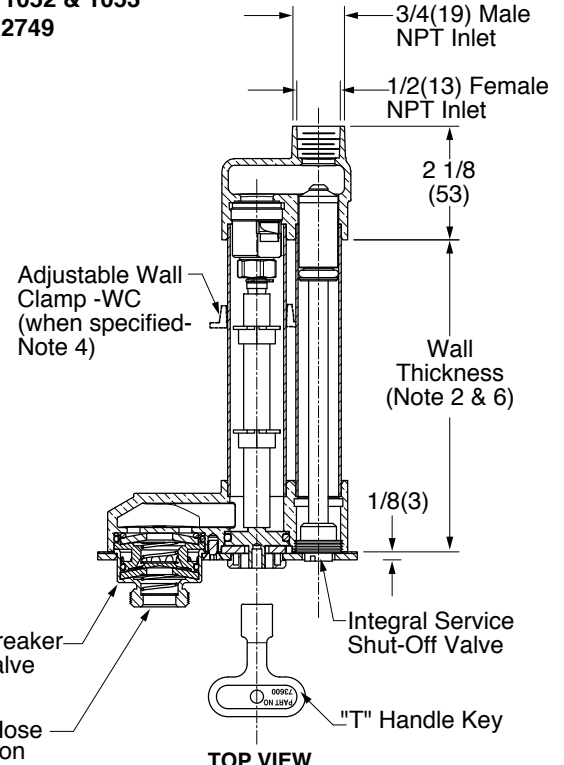

NOTE: Dimensions shown in parentheses are in millimeters.

REGULARLY FURNISHED:

Bronze Quarter Turn Non-Freeze Automatic Draining Hydrant with Stainless Steel Face, Hose Connection, Integral Vacuum Breaker, Integral Service Shut-Off Valve, Dual Check Valve and "T" Handle Key.

VARIATIONS:

- Adjustable Wall Clamp -WC (Note 4)
- 1" Hose Connection -HC1
- 1" Male NPT Inlet Connection -IC1 (Note 5)
- Mild Climate -SAP (Note 6)
- Wheel Handle -WH

OPTIONAL MATERIALS:

- Polished Bronze Face -PB
- Chrome Plated Face -CP

PATENT NO. 8,973,599
 PATENT NO. 10, 017,921

J	4-20-20	Revised Notes	TBW	CL
F	7-26-18	Added Patent No.	TBW	TWK
	4-5-18	Added Note	TBW	TWK
	5-11-15	Added Patent No.	TBW	TWK
REV.	DATE	DESCRIPTION	BY	CKD. BY

WEIGHT POUNDS	VOLUME CUBIC FEET

FIGURE NUMBER	5615
---------------	------

DRAWING NUMBER: 5615
 SIZE: A
 SCALE: NONE
 DATE: 11-29-11
 APPROVED BY: CL
 CHECKED BY: CL
 DRAWN BY: TBW
 DIMENSIONS ARE SUBJECT TO MANUFACTURERS TOLERANCE AND CHANGE WITHOUT NOTICE
 FIGURE NUMBER: 5615

GUARDIAN PLUS DUAL CHECK WALL HYDRANT PARTS LIST

DRAWING NUMBER: 5615BS
 SIZE: A
 SCALE: NONE
 DATE: 11-29-11
 APPROVED BY: CL
 CHECKED BY: CL
 DRAWN BY: TBW
 DIMENSIONS ARE SUBJECT TO MANUFACTURERS TOLERANCE AND CHANGE WITHOUT NOTICE
 WE CAN ASSUME NO RESPONSIBILITY FOR USE OF SUPERSEDED OR VOID DATA

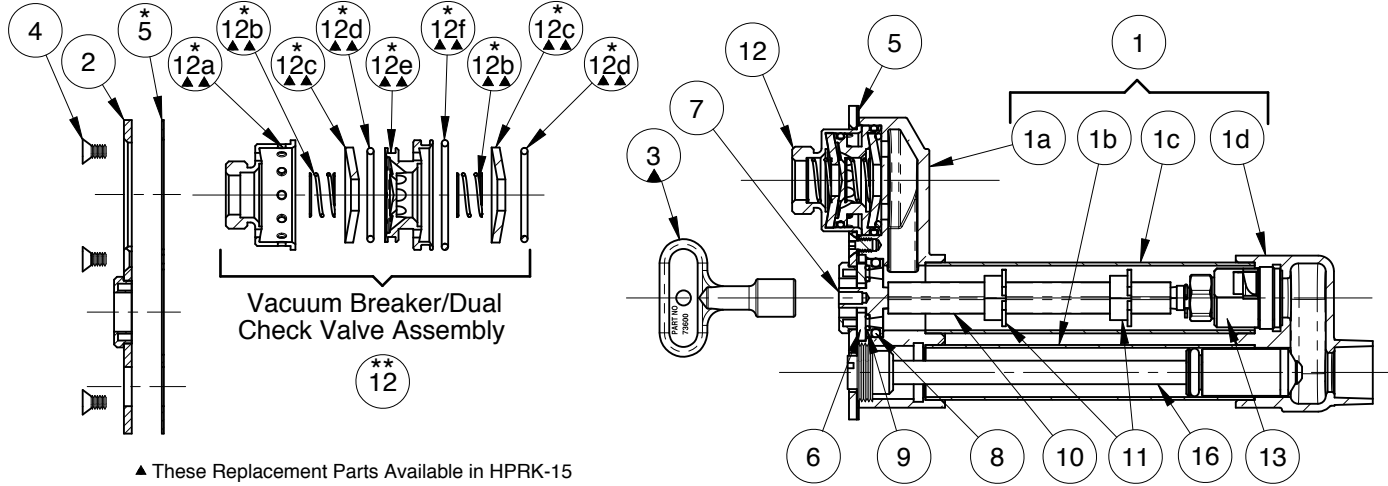

- ▲ These Replacement Parts Available in HPRK-15
- ▲▲ These Replacement Parts Available in HPRK-19VB
- ▲▲▲ These Replacement Parts Available in HPRK-15SV
- * These Parts Accessible from Face of Hydrant by Removing Wall Plate Assembly.
- ** Parts supplied as an assembly only, see part 12, 13 or 16.

Installer is responsible for providing a 100% watertight positive seal at the hydrant to wall interface. Seal all the flange with an appropriate sealant recommended by a sealant manufacturer. NOTE: Jay R. Smith does not warrant the performance or life expectancy of the sealant material.

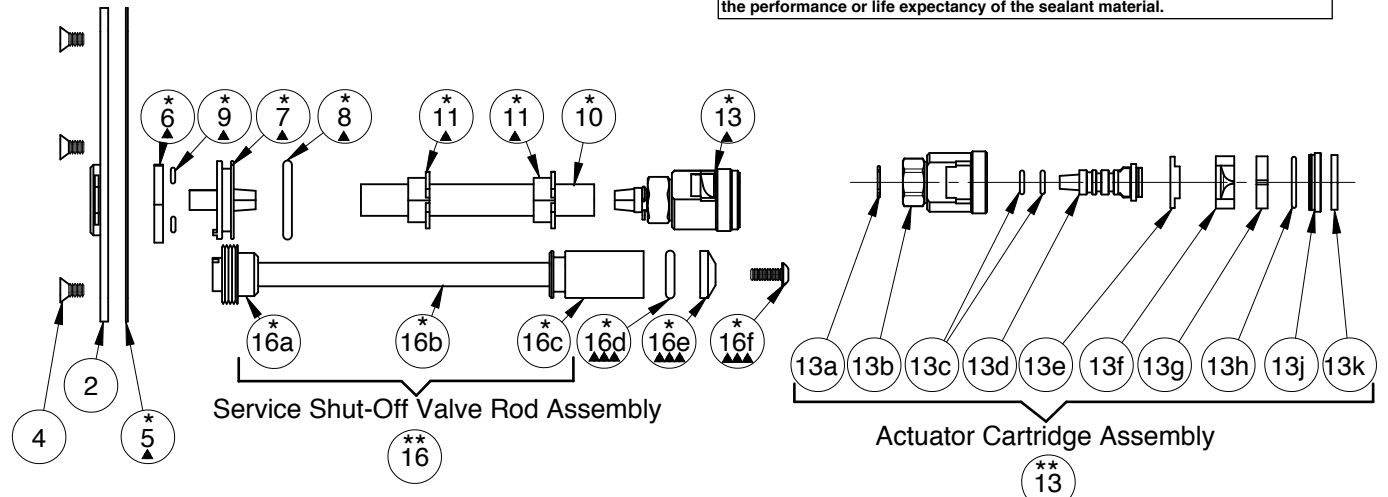

HYDRANT PARTS LIST							
NO.	DESCRIPTION	NO.	DESCRIPTION	NO.	DESCRIPTION	NO.	DESCRIPTION
1	Casing Assembly	8	Movable Operator O-Ring	12e	**Flow Diverter	13h	**O-Ring
1a	Head	9	Drain Hole Seal (2)	12f	**Large O-Ring	13j	**O-Ring Gasket Retainer
1b	Casing	10	Operator Rod	13	Actuator Cartridge Assembly	13k	**Rubber Seal
1c	Casing	11	Operator Rod Guides (2)	13a	**Retaining Ring	16	Service Valve Rod Assembly
1d	Valve Housing	12	Vacuum Breaker/Dual Check Valve Assembly	13b	**Valve Body	16a	**Service Valve Operator
2	Wall Plate Assembly	12a	**Vacuum Breaker Housing	13c	**Actuator O-Ring (2)	16b	**Service Valve Rod
3	Key	12b	**Spring (2)	13d	**Valve Actuator	16c	**Service Valve Plunger
4	Wall Plate Securing Screw (5)	12c	**Cone Washer (2)	13e	**Nylon Thrust Washer	16d	Service Valve O-Ring
5	Wall Plate Gasket	12d	**Small O-Ring	13f	**Rotating Ceramic Disc	16e	Service Valve Conical Washer
6	Stationary Operator Piece			13g	**Fixed Ceramic Disc	16f	Service Valve Washer Screw
7	Movable Operator Piece						

FIGURE NUMBER	C B A	4-5-18 4-23-14 2-21-12	Added Note Rev. Note Rev. Title	TBW TBW TBW	BW CL CL	WEIGHT POUNDS	VOLUME CUBIC FEET	FIGURE NUMBER 5615BS
REV.	DATE	DESCRIPTION	BY	CKD. BY				