

# FLOOR CLEANOUTS WITH "TWIS-TO-FLOOR"® ADJUSTABLE TOPS FOR UNFINISHED AREAS

## ROUND CAST IRON TOP - TRACTOR COVER

**FUNCTION:** Used in unfinished areas where a loose set, non-tilt tractor cover is desired. Will withstand heavy load traffic.

DRAWING NUMBER: S4237  
SIZE: A  
SCALE: NONE  
DATE: 2-16-70  
APPROVED BY: JM  
CHECKED BY: BH  
DRAWN BY: RK

WE CAN ASSUME NO RESPONSIBILITY FOR USE OF SUPERSEDED OR VOID DATA  
DIMENSIONS ARE SUBJECT TO MANUFACTURERS TOLERANCE AND CHANGE WITHOUT NOTICE

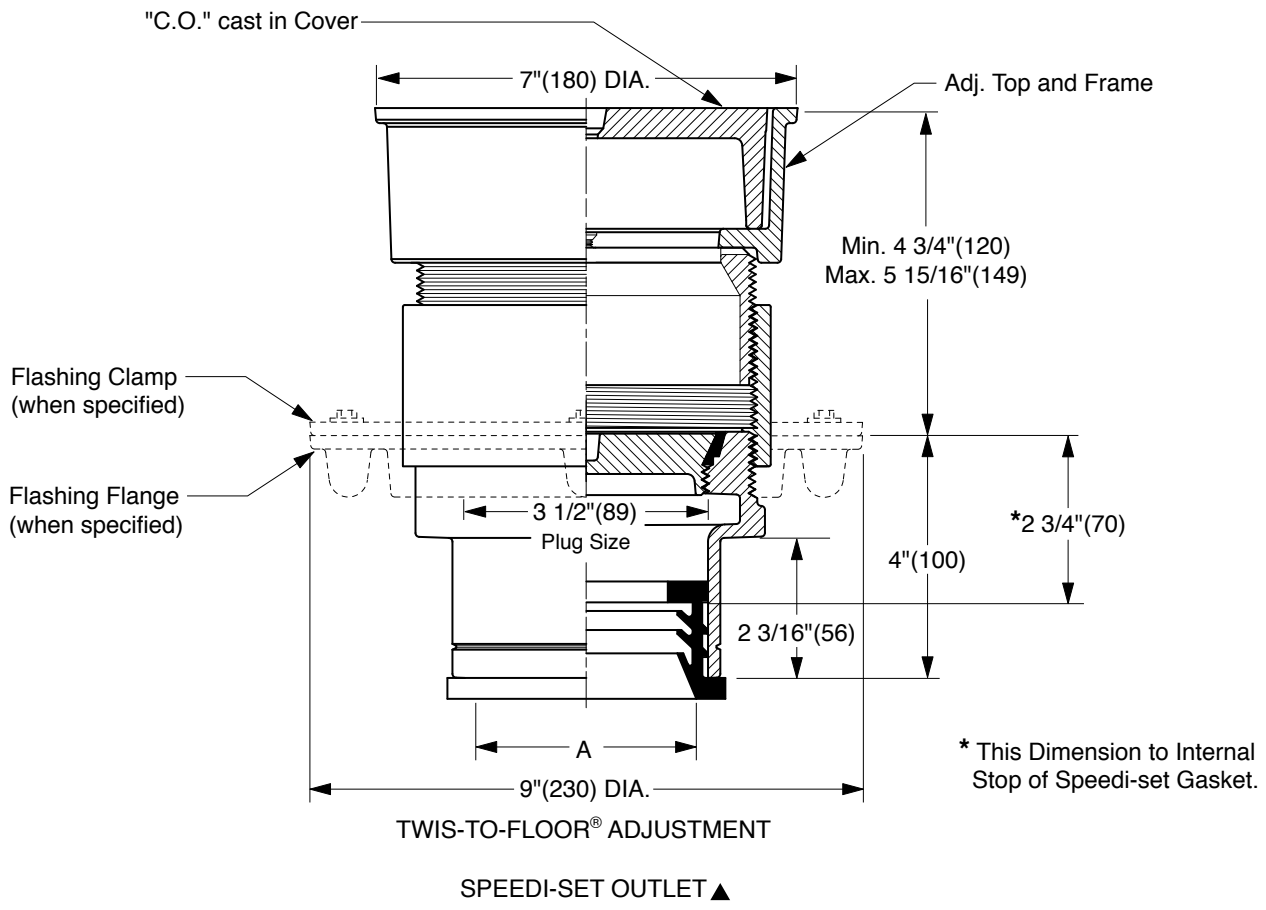

"A" (Pipe Size) = 02(50), 03(75) or 04(100)

- |                          |   |  |
|--------------------------|---|--|
| <input type="checkbox"/> | Fig. 4237L.....Gasket Seal - ABS Plug     | (Twis-to-Floor® design shown with gasketed plug.)                |
| <input type="checkbox"/> | Fig. 4238L.....Gasket Seal - Bronze Plug  | <b>NOTE:</b> Dimensions shown in parentheses are in millimeters. |
| <input type="checkbox"/> | Fig. 4239L.....Taper Thread - Bronze Plug | ▲ Available in Extra Heavy, Service Weight or NO-HUB.            |
| <input type="checkbox"/> | Fig. 4236L.....Taper Thread - ABS Plug    |  |

**REGULARLY FURNISHED:**  
 Duco Cast Iron Cleanout with Round Adjustable Scoriated Cast Iron Top with Non-Tilt Tractor Cover. Closure Plug Type as Indicated by Figure Number Selected.

- VARIATIONS:**
- |                          |                                       |
|--------------------------|---------------------------------------|
| <input type="checkbox"/> | Center Securing Screw -CSS            |
| <input type="checkbox"/> | Vandal Proof Center Securing Screw -U |
| <input type="checkbox"/> | Flashing Flange -F                    |
| <input type="checkbox"/> | Flange with Flashing Clamp -F-C       |

- OPTIONAL MATERIALS:**
- |                          |                         |
|--------------------------|-------------------------|
| <input type="checkbox"/> | Galvanized Cast Iron -G |
| <input type="checkbox"/> | Ductile Iron Cover -M   |
| <input type="checkbox"/> | Nickel Bronze Top -NB   |
| <input type="checkbox"/> | Polished Bronze Top -PB |

FIGURE NUMBER	N M L	07/29/02 04/12/01 10/31/00	Corrected Clamp & Flange view Added dimension and note New design	JJ JJ JJ	CL CL BS	WEIGHT POUNDS	VOLUME CUBIC FEET	<b>FIGURE NUMBER</b> <b>4237 SERIES</b>
REV.	DATE	DESCRIPTION	BY	CKD. BY				

# FLOOR CLEANOUTS WITH "TWIS-TO-FLOOR®" ADJUSTABLE TOPS FOR UNFINISHED AREAS

## ROUND CAST IRON TOP - TRACTOR COVER

**FUNCTION:** Use in unfinished areas where a loose set, non-tilt tractor cover is desired. Will withstand heavy load traffic.

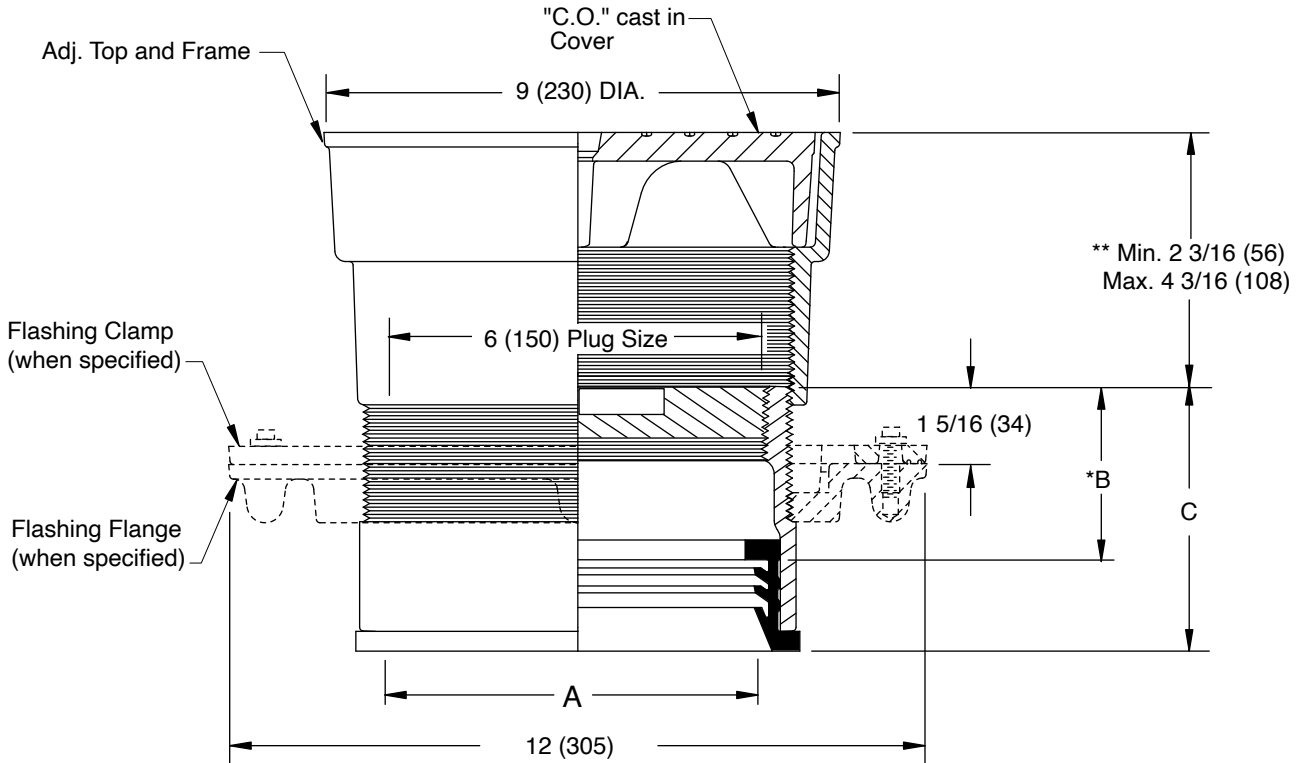

**SPEEDI-SET OUTLET ▲**

"A" (Pipe Size) = 06(150) & 08(200)

A SIZE	B	C
06(150)	*3(76)	4 9/16(117)
08(200)	*3 1/4(83)	4 13/16(121)

**"TWIS-TO-FLOOR®" ADJUSTMENT**

**SPEEDI-SET OUTLET ▲**

Fig. 4239L.....Taper Thread - Bronze Plug

**▲ SPEEDI-SET OUTLET**

- L Service Weight - For Service Weight and No Hub Cast Iron Pipe (Available for all pipe sizes)
- LXH Extra Heavy - For Extra Heavy Cast Iron Pipe (Available for all pipe sizes)
- LXH Extra Heavy - For PVC Pipe (Available for 2", 3", 4", and 8" pipe sizes only)
- LPVC Plastic Pipe - For PVC or ABS pipe (Available for 6" pipe size only)

\* This Dimension to Internal Stop of Speedi-Set Gasket.

\*\* When Flange-F is specified Min. 2 3/16 (56) becomes 2 11/16 (68)

**REGULARLY FURNISHED:**

Duco Cast Iron Cleanout with Taper Thread Bronze Plug and Round Adjustable Scoriated Cast Iron Top with Non-Tilt Tractor Cover.

**VARIATIONS:**

- Flashing Flange -F
- Flange with Flashing Clamp -F-C
- Vandal Proof Top -U
- Center Securing Screw -CSS

**OPTIONAL MATERIALS:**

- Galvanized Cast Iron -G
- Polished Bronze Top -PB
- Nickel Bronze Top -NB
- Ductile Iron Cover -M

**NOTE:** Dimensions shown in parentheses are in millimeters.

DRAWING NUMBER  
S4237BS

SIZE  
A

SCALE:  
NONE

DATE:  
5-5-06

APPROVED BY:  
CEL

CHECKED BY:  
CL

DRAWN BY:  
RN

FIGURE NUMBER  
4239

WE CAN ASSUME NO RESPONSIBILITY FOR USE OF SUPERSEDED OR VOID DATA

REV.	DATE	DESCRIPTION	BY	CKD. BY
A	10-9-2020	Rev./Added New ▲Note	MW	CR

WEIGHT POUNDS	VOLUME CUBIC FEET
---------------	-------------------

<b>FIGURE NUMBER</b> <b>4239</b>
-------------------------------------