

PARKING DECK FLOOR DRAINS WITH HEAVY DUTY WIDE FLANGE COLLAR FOR PRECAST SLABS

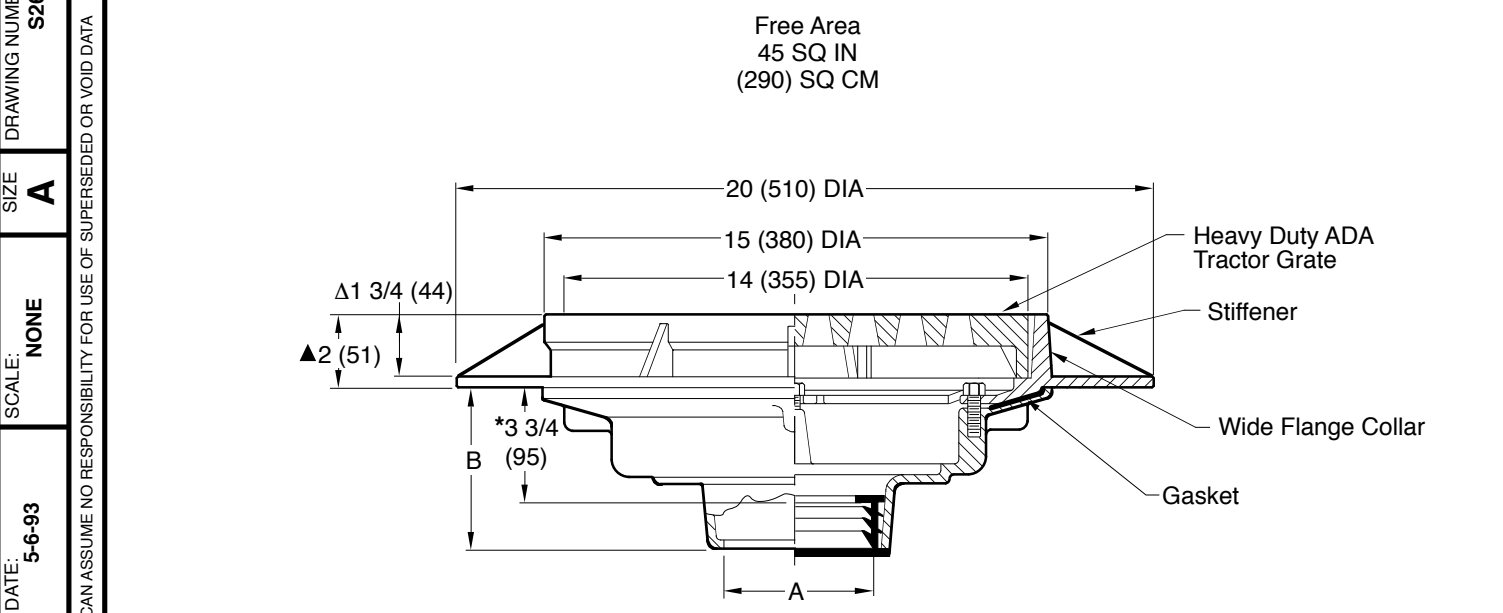

- Fig. 2624C CAULK OUTLET
- Fig. 2624Y NO-HUB OUTLET
- Fig. 2624T THREADED OUTLET

recommended deck opening - 16" (405) DIA
 *This dimension to internal stop of Speedi-Set gasket.
 ▲Add 1/4" (6) when bronze top is specified.

A SIZE	02(50), 03(75), 04(100), 05(125), or 06(150)	08(200)
B	5 (125) for Caulk, NO-HUB and Speedi-Set. 3 3/4 (95) for Threaded	6 (150) for Caulk and NO-HUB 5 (125) for Threaded

- REGULARLY FURNISHED:**
 Duco Cast Iron Body, Heavy Duty Wide Flange Collar with Heavy Duty ADA Tractor Grate. Gasket Seal Between Body and Collar.
- VARIATIONS:**
- Dome Bottom Strainer -DBS
 - Cast Iron Flat Bottom Strainer -FBSCI
 - Side Outlet (Specify Fig. 2629)
 - Square Top -S
 - Vandal Proof -U
 - L Speedi-Set Service Weight
02(50), 03(75) & 04"(100) sizes only
 - LXH Speedi-Set Extra Heavy
02(50), 03(75) & 04"(100) sizes only
 - Bucket -B
 - Quad Close Trap Seal (Specify Fig. 2692)
- OPTIONAL MATERIALS:**
- Ductile Iron Grate -M
 - Galvanized Cast Iron -G
 - Nickel Bronze Top -NB
 - Polished Bronze Top -PB

NOTE: Dimensions shown in parentheses are in millimeters.

FIGURE NUMBER	2624	REV.	DATE	DESCRIPTION	BY	CKD. BY	WEIGHT POUNDS	VOLUME CUBIC FEET	FIGURE NUMBER
		N	6-15-2020	Rev. Variations, Added Outlet Option	MW	CL			2624
M	1-30-18	Rev. Reg. Furn., Title, Var., Added Gasket	TBW	CL					
L	1-18-18	Rev. Reg. Furn., Title, Callout	TBW	CL					
K	7-10-15	Revised Variations	TBW	CL					