

FLOOR DRAINS AND ACCESSORIES

200 Series

PVC Floor Drain, Series 225

TAG _____

Product Description: Recommended for use in light traffic areas where a shallow drain is required. This floor drain is produced from high strength, chemically resistant PVC; ensuring it is tough, durable and capable of withstanding job site abuse. The floor drain consists of an 8" diameter grate, body, seepage holes, sediment bucket, flange and flashing clamp. In on-grade applications the flange acts as an anchor. When installed in waterproof floors, the flashing clamp is used for clamping of membrane.

Features and Benefits:

- PVC offers excellent resistance to chemicals, will not chip, rust or corrode
- Light weight facilitates transportation, handling, and installation
- Can be adapted to all types of floor construction and finishes
- Medium duty load rating
- IAPMO Listed, File No. 3978

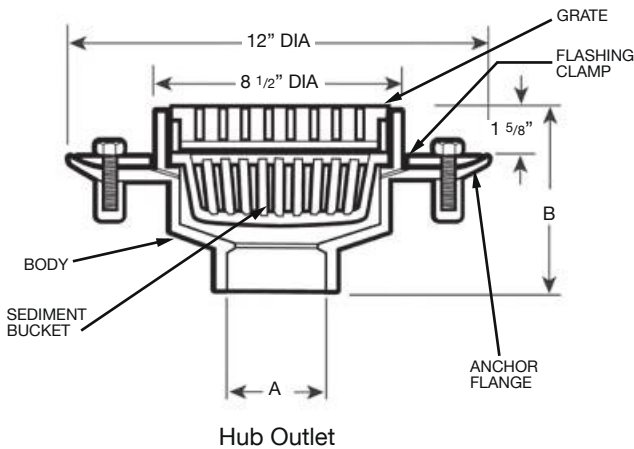

Series 225

Series Number	Material Type	Description	A Outlet Size	B	Outlet Type
225-H03	PVC	Floor Drain Body, Grate, and Sediment Bucket	3"	5 13/16"	Hub
225-H04	PVC	Floor Drain Body, Grate, and Sediment Bucket	4"	6 1/16"	Hub
225-10	PVC	Grate	-	-	-
225-11	PVC	Sediment Bucket	-	-	-

NOTE: Dimensional data is subject to manufacturing tolerances and change without notice.



A Product of:
JAY R. SMITH MFG. CO.
 DIVISION OF SMITH INDUSTRIES, INC.
www.jrsmith.com



Series 225

SPM 1013

11/14

WARNING: Cancer and Reproductive Harm - www.P65Warnings.ca.gov