



JAY R. SMITH MFG. CO.
 MEMBER OF MORRIS GROUP INTERNATIONAL
 POST OFFICE BOX 3237
 MONTGOMERY, ALABAMA 36109-0237 (USA)
 TEL: 334-277-8520 FAX: 888-377-7818 www.jrsmith.com



MEMBER OF:

LOCATION

FLOOR DRAINS

12" (305) ROUND TOP SOLID FREE STANDING SEDIMENT BUCKET

Free Area
 29 SQ IN
 (187) SQ CM

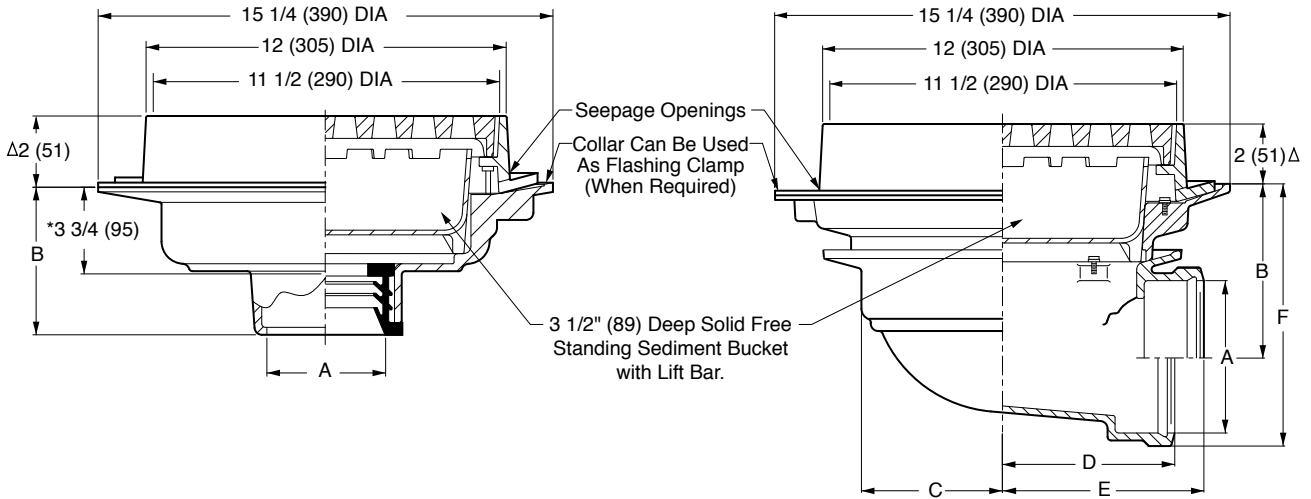

- Fig. 2142C.....CAULK OUTLET
- Fig. 2142T.....THREADED OUTLET
- Fig. 2142Y.....NO-HUB OUTLET

- Fig. 2147C.....CAULK OUTLET
- Fig. 2147T.....THREADED OUTLET

| A Size | B | |
|--------------------------------------|----------------------------|------------|
| | Caulk, NO-HUB & Speedi-Set | Threaded |
| 02(50,03(75)04(100)05(125) & 06(150) | 5 (125) | 3 3/4 (95) |

| A SIZE | 02(50) | 03(75) | 04(100) | 05(125) | 06(150) |
|--------|------------|------------|------------|------------|------------|
| B | 6 7/8(175) | 6 3/8(162) | 5 7/8(149) | 5(125) | 4 1/2(115) |
| C | 4 3/4(120) | 4 3/4(120) | 4 3/4(120) | 6 1/4(160) | 6 1/4(160) |
| D | 6(150) | 6(150) | 6(150) | 6 5/8(168) | 6 7/8(175) |
| E | 7 1/4(185) | 7 1/2(190) | 7 3/4(195) | 7 3/4(195) | 7 3/4(195) |
| F | 8 5/8(219) | 8 3/4(220) | 8 3/4(220) | 8 1/2(215) | 8 1/2(215) |

REGULARLY FURNISHED:

Duco Cast Iron Body and Flashing Collar with Medium Duty Cast Iron Tractor Grate and Solid Free Standing Sediment Bucket.

**For Heavy Duty: Specify Ductile Iron Grate-M.

ΔAdd 1/8" (3) when bronze top is specified.

*This dimension to internal stop of Speedi-Set gasket.

VARIATIONS:

- Flat Bottom Strainer -FBS
- L Speedi-Set Service Weight 02(50), 03(75) & 04"(100) sizes only. (Fig. 2142 only)
- LXH Speedi-Set Extra Heavy 02(50), 03(75) & 04"(100) sizes only. (Fig. 2142 only)
- NO-HUB Adaptor (Specify Fig. 2646Y) (Fig. 2140 & 2147 only)
- Seepage Holes in Bucket -FP (Frost Proof)
- Square Top -S
- Trap Primer Connection -P050 1/2" (13) & -P075 3/4" (19) (Fig. 2142 only)
- Vandal Proof Grate -U
- Heel Proof Grate -Q45
- Quad Close Trap Seal (Specify Fig. 2692) (Fig. 2142 Only)

OPTIONAL MATERIALS:

- Ductile Iron Grate -M
- Galvanized Cast Iron -G
- Nickel Bronze Top -NB
- Polished Bronze Top -PB

NOTE: Fig. 2147 in 02(50), 03(75), & 04"(100) sizes require a transition collar (as shown in above illustration) which fits between the body & collar. 05(12) & 06"(150) sizes do not require transition collar.

NOTE: Dimensions shown in parentheses are in millimeters.

DRAWING NUMBER
S2142, 2147

SIZE
A

SCALE:
NONE

DATE:
5-17-85

APPROVED BY:
TD

CHECKED BY:
TD

DRAWN BY:
BS

2142, 2147

FIGURE NUMBER

M 5-27-21
L 9-11-19
K 7-22-19
J 6-17-19

Rem. Note & Added to Reg. Furn
Rev. Fig Opt., Var. & Note
Added Load Rating
Removed Function

KK MW
MW MW
MW MW

JT JM
JM JM
JM JM

WEIGHT
POUNDS

VOLUME
CUBIC FEET

FIGURE NUMBER

2142, 2147



WARNING: Cancer and Reproductive Harm - www.P65Warnings.ca.gov