

N



**JAY R. SMITH MFG. CO.**  
 MEMBER OF MORRIS GROUP INTERNATIONAL  
 POST OFFICE BOX 3237  
 MONTGOMERY, ALABAMA 36109-0237 (USA)  
 TEL: 334-277-8520 FAX: 888-377-7818 www.jrsmith.com



MEMBER OF:



LOCATION

DRAWING NUMBER

s2120

SIZE

A

SCALE:

NONE

DATE:

5-17-85

APPROVED BY:

TD

CHECKED BY:

TD

DRAWN BY:

PJ

**2120, 2125**

WE CAN ASSUME NO RESPONSIBILITY FOR USE OF SUPERSEDED OR VOID DATA

# FLOOR DRAINS

## 8 1/2" (215) ROUND TOPS

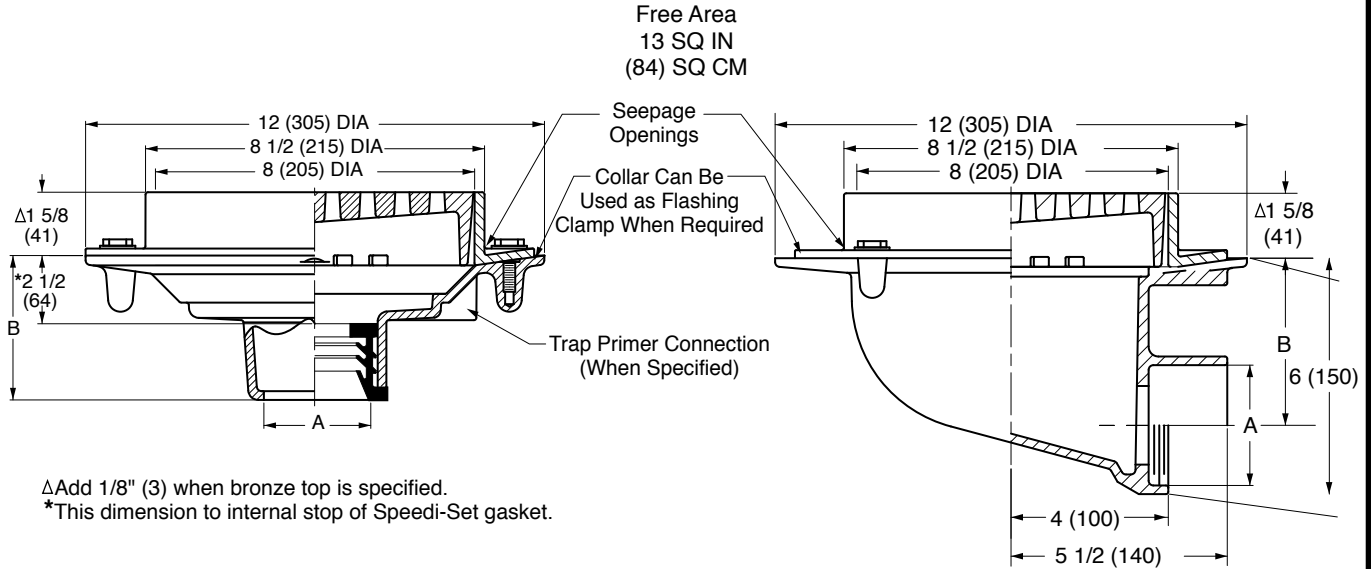

Free Area  
 13 SQ IN  
 (84) SQ CM

ΔAdd 1/8" (3) when bronze top is specified.  
 \*This dimension to internal stop of Speedi-Set gasket.

- Fig. 2120C.....CAULK OUTLET
- Fig. 2120Y.....NO-HUB OUTLET
- Fig. 2120T.....THREADED OUTLET

- Fig. 2125C.....CAULK OUTLET
- Fig. 2125T.....THREADED OUTLET

A SIZE	02 (50)	03 (75)	04 (100)	06 (150)
B	3 3/4 (95) for Caulk, NO-HUB, and Speedi-Set, 2 (51) for Threaded		3 3/4 (95) NO-HUB Only	

A SIZE	02(50)	03(75)	04(100)
B	4 1/4(110)	3 3/4(95)	3 1/4(83)

### REGULARLY FURNISHED:

Duco Cast Iron Body and Flashing Collar with Medium Duty Cast Iron Tractor Grate.

\*\*For Heavy Duty: Specify Ductile Iron Grate-M.

### VARIATIONS:

- Closure Plug -XP (Fig. 2110 only)
- Dome Grate -D
- Flat Bottom Strainer -FBS (Fig. 2120 only)
- L Speedi-Set Service Weight (Fig. 2120 only)
- LXH Speedi-Set Extra Heavy (Fig. 2120 only)
- NO-HUB Adaptor (Specify Fig. 2646Y) (Fig. 2125 only)
- Sediment Bucket -B
- Square Top -S
- Trap Primer Connection -P050 1/2" (13) & -P075 3/4" (19)
- Vandal Proof Grate -U
- Heel Proof Grate -Q45
- Quad Close Trap Seal (Specify Fig. 2692) (Fig. 2120 Only)

### OPTIONAL MATERIALS:

- Ductile Iron Grate -M
- Galvanized Cast Iron -G
- Nickel Bronze Top -NB
- Polished Bronze Top -PB

**NOTE:** Dimensions shown in parentheses are in millimeters.  
 \*Not available on Fig. 2120T threaded outlet drain.

FIGURE NUMBER

N 5-27-21  
 M 9-11-19  
 L 7-22-19  
 K 6-17-19

Rem. Note & Added to Reg. Fur. Rev. Fig.Opts and Variations Added Load Rating Removed Function

KK  
 MW  
 MW  
 MW

JT  
 CL  
 JM  
 JM

WEIGHT POUNDS

VOLUME CUBIC FEET

FIGURE NUMBER

# 2120, 2125

CKD



**WARNING:** Cancer and Reproductive Harm - www.P65Warnings.ca.gov