



**JAY R. SMITH MFG. CO.**  
 MEMBER OF MORRIS GROUP INTERNATIONAL  
 POST OFFICE BOX 3237  
 MONTGOMERY, ALABAMA 36109-0237 (USA)  
 TEL: 334-277-8520 FAX: 888-377-7818 www.jrsmith.com



LOCATION

# FLOOR DRAIN WITH DECK EXTENSION PLATE

DRAWING NUMBER  
2039-DEP

SIZE  
A

SCALE:  
NONE

DATE:  
12-14-2020

APPROVED BY:  
AM

CHECKED BY:  
CL

DRAWN BY:  
CL

FIGURE NUMBER  
2039-DEP

WE CAN ASSUME NO RESPONSIBILITY FOR USE OF SUPERSEDED OR VOID DATA

DIMENSIONS ARE SUBJECT TO MANUFACTURERS TOLERANCE AND CHANGE WITHOUT NOTICE

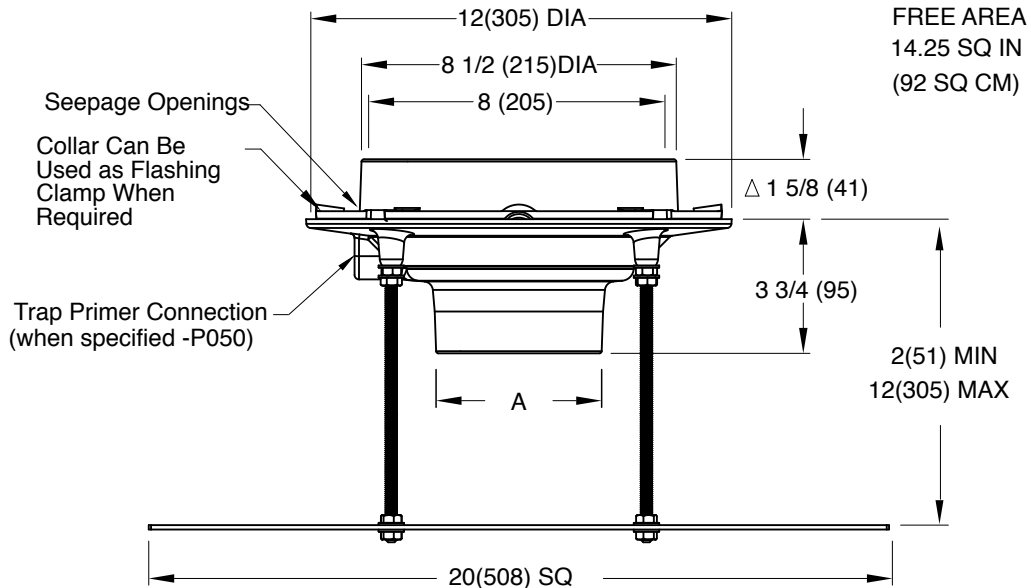
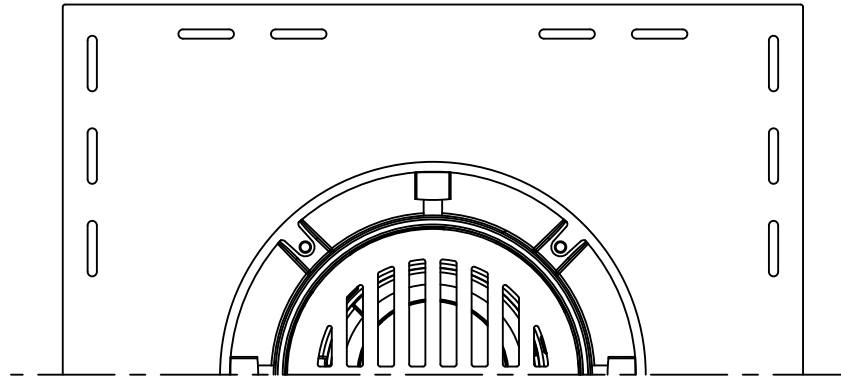

- Fig. 2039L-DEP . . SPEEDI-SET SW OUTLET
- Fig. 2039LXH-DEP . . SPEEDI-SET XH OUTLET
- Fig. 2039Y-DEP . . NO-HUB OUTLET

**REGULARLY FURNISHED:**

Duco Cast Iron Body and Flashing Collar with Cast Iron Bar Grate. And Deck Extension Plate.

**VARIATIONS:**

- Vandal Proof Grate -U
- Dome Grate -D
- Sediment Bucket -B
- Flat Bottom Strainer -FBS
- Trap Primer Connection -P050 1/2"(13) & -P075 3/4"(19)
- Tractor Grate -TG

**OPTIONAL MATERIALS:**

- Ductile Iron Grate -M
- Galvanized Cast Iron -G
- Nickel Bronze Top -NB
- Polished Bronze Top -PB

Δ Add 3/16"(5) When Bronze Top Is Specified.

REV.	DATE	DESCRIPTION	BY	CKD. BY

WEIGHT POUNDS	VOLUME CUBIC FEET

FIGURE NUMBER <b>2039-DEP</b>
----------------------------------