

B

SMITH® JAY R. SMITH MFG. CO.®
 MEMBER OF MORRIS GROUP INTERNATIONAL
 POST OFFICE BOX 3237
 MONTGOMERY, ALABAMA 36109-0237 (USA)
 TEL: 334-277-8520 FAX: 334-272-7396 www.jrsmith.com



LOCATION

8 1/2" AND 12" DIAMETER TOP DRAINS WITH FormIt® DRAIN INSTALLATION DEVICE

FUNCTION: The Jay R. Smith Mfg. Co.® FormIt® Drain Installation Device is designed to stabilize the drain and provide adjustment during the installation process and allows final connection of outlet piping to drain after the concrete pour.

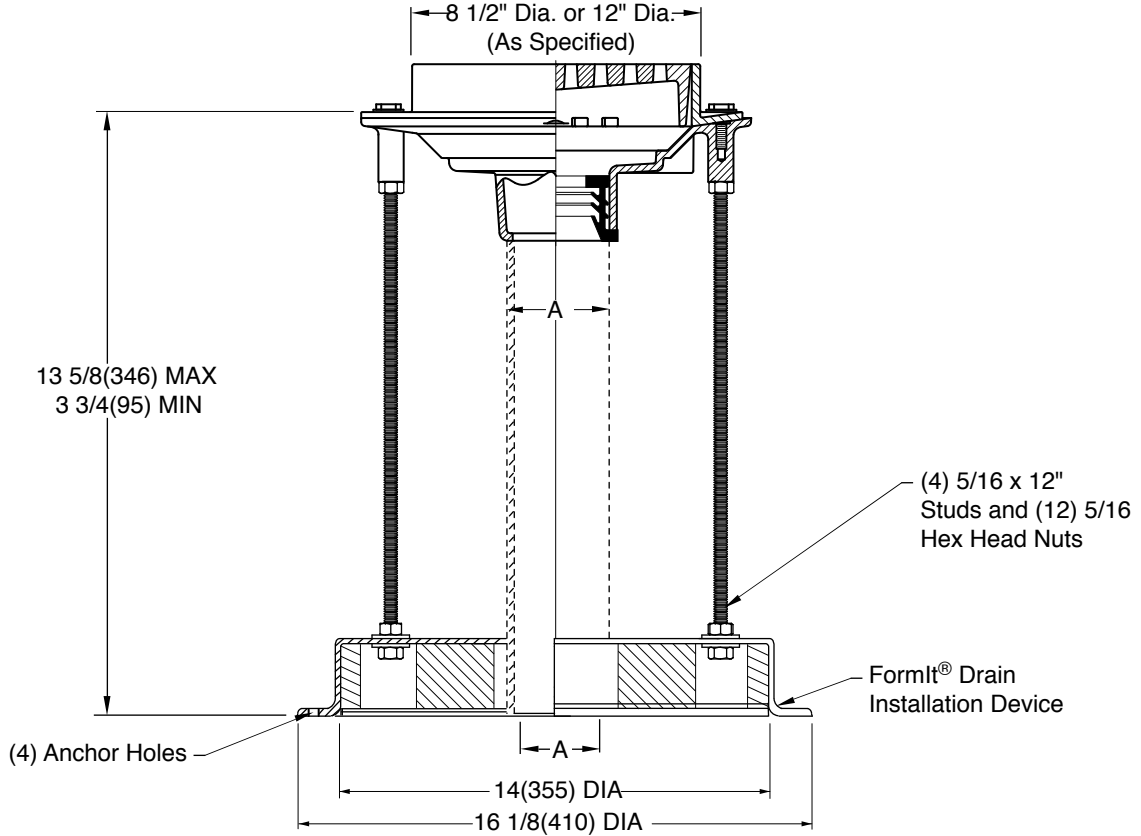

A= Pipe Size 02, 03, 04 and 06

NOTE: Designed To Be Used With Smith 8 1/2" and 12" Round Top Drains.

REGULARLY FURNISHED:

Specify (8 1/2" or 12" Dia. Top) Cast Iron Floor Drain with FormIt® Drain Installation Device and Hardware. Stud Holes on 9 3/4" Bolt Circle for 8 1/2" Dia. Top Drains and 13 3/16" Bolt Circle for 12" Dia. Top Drains.

VARIATIONS:

- L Speedi-Set Service Weight 02(50), 03(80) & 04"(100) sizes only
- LXH Speedi-Set Extra Heavy 02(50), 03(80) & 04"(100) sizes only
- Square Top -S
- Trap Primer Connection -P050 1/2"(13) & -P075 3/4"(19)
- Vandal Proof Grate -U
- T Threaded Outlet

OPTIONAL MATERIALS:

- Ductile Iron Grate -M
- Galvanized Cast Iron -G
- Nickel Bronze Top -NB
- Polished Bronze Top -PB

NOTE: Dimensions shown in parentheses are in millimeters.

DRAWING NUMBER s2039

SIZE A

SCALE: NONE

DATE: 8-27-08

APPROVED BY: BW

CHECKED BY: BW

DRAWN BY: RN

WE CAN ASSUME NO RESPONSIBILITY FOR USE OF SUPERSEDED OR VOID DATA

DIMENSIONS ARE SUBJECT TO MANUFACTURERS TOLERANCE AND CHANGE WITHOUT NOTICE

2039

FIGURE NUMBER	B A	7-7-10 05/14/09	Revised™ to® Added Function	RN JJ	BW BW
REV.	DATE	DESCRIPTION		BY	CKD. BY

WEIGHT POUNDS	VOLUME CUBIC FEET

FIGURE NUMBER
2039