

FLOOR OR SHOWER DRAINS WITH ADJUSTABLE STRAINER HEADS

General service floor drain for use in showers, toilets, kitchens and other finished areas where foot traffic is expected.

Load Rating: Light Duty having a Safe Live (Static) Load less than 2,000 lbs. (900 kg) per ASME A112.6.3 Floor Drain Standard. For the specific Safe Live Load rating of any grate, contact the Smith representative or factory direct.

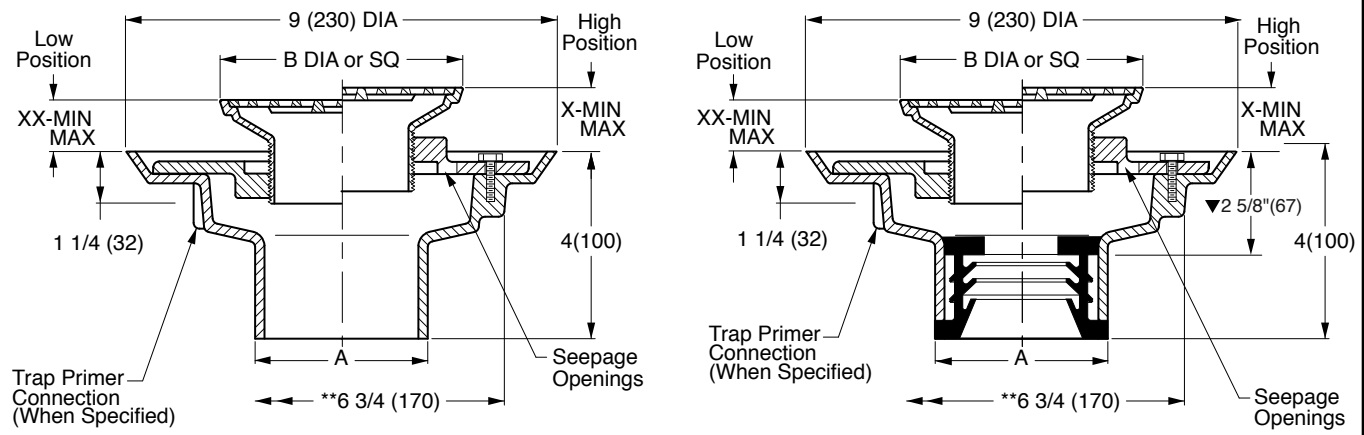

A (Pipe Size) = 02(50), 03(75), 04(100), 05(125) or 06(150)

NO-HUB OUTLET

- Fig. 2005Y.....(A) ROUND TOP
- Fig. 2005Y.....(B) SQUARE TOP

SPEEDI-SET OUTLET

- Fig. 2005L.....(A) ROUND TOP
- Fig. 2005L.....(B) SQUARE TOP

Outlet Size	Nickel Bronze Strainer Head
▲ 02(50)	05(125) DIA or SQ
▲ 03(75)	06(150) DIA or SQ
▲ 04(100)	08(205) DIA or SQ

Strainer Size	*Collar In High Position		*Collar In Low Position		Free Area SQ IN (SQ CM)	
	B	X	XX	XX	ROUND	SQUARE
05 (125)	1 1/4(32)	2 1/4(57)	3/4(19)	1 5/8(41)	7(45)	6.5(42)
06 (150)	1 1/4(32)	2 1/4(57)	3/4(19)	1 5/8(41)	9(58)	12.5(81)
07 (180)	1 1/4(32)	2 1/4(57)	7/8(22)	1 7/8(48)	14(90)	11(71)
08 (205)	1 1/2(38)	2 1/2(64)	1(25)	1 7/8(48)	17(110)	14(90)
*09 (230)	1 1/2(38)	2 3/8(60)	1(25)	1 7/8(48)	18(116)	16(103)
*10 (255)	1 1/2(38)	2 3/8(60)	1(25)	1 7/8(48)	23(48)	16(103)

- ▼ This dimension to internal stop of speedi-set gasket.
- * Add 3/8"(10) to all min/max dimensions for round strainers.
- * Collar is reversible to obtain extreme high and low strainer positions.
- ** Not available for 5"(125) size strainer.
- ** MIN 6 3/4"(170) hole required for core drilled application.

REGULARLY FURNISHED:
 Duco Cast Iron Body with Flashing Collar and Adjustable Strainer Head as Indicated by Suffix Letter Selected.

- VARIATIONS:**
- Flapper Type Backwater Valve -V (NOTE 2)
 - Hinged Grate -H (NOTE 1)
 - L Speedi-Set Service Weight 2(50), 3(75) & 4"(100) only
 - LXH Speedi-Set Extra Heavy 2(50), 3(75) & 4"(100) only
 - Sediment Bucket -B
 - Trap Primer Connection -P050 1/2" (13) & -P075 3/4" (19)
 - Vandal Proof Screws -U
 - Wide Flanged Strainer (Specify Fig. DX2005)
 - T Threaded Outlet (Specify 2010T)
 - Heelproof Grate -HP -AHP (Round) or -BHP (Square)
 - Quad Close Trap Seal (Specify Fig. 2692)

- OPTIONAL MATERIALS:**
- Bronze Body -BB
 - Chrome Plated Strainer -CP
 - Galvanized Cast Iron Body -G
 - Nickel Bronze Strainer -NB
 - Polished Bronze Strainer -PB
 - All Stainless Steel (Specify Fig. 9700)
 - Stainless Steel Strainers -SS [Available in 05(125) & 06(150) sizes only]

NOTE: Dimensions shown in parentheses are in millimeters.
 ▲ Meets ASME Standard A112.6.3-2001 02(50), 03(75) or 04"(100) sizes only.

NOTE 1: Sediment Bucket -B not provided for a Hinged Grate (-H)

NOTE 2: Sediment Bucket -B not provided for a Ball Float (-BFV) or a Flapper Type (-V)

SEE PM 0457 FOR OPTIONAL STRAINER HEADS.

DRAWING NUMBER S2005
 SIZE A
 SCALE: NONE
 DATE: 5-17-85
 APPROVED BY: TD
 CHECKED BY: TD
 DRAWN BY: PJ
 FIGURE NUMBER 2005
 DIMENSIONS ARE SUBJECT TO MANUFACTURERS TOLERANCE AND CHANGE WITHOUT NOTICE
 WE CAN ASSUME NO RESPONSIBILITY FOR USE OF SUPERSEDED OR VOID DATA

REV.	DATE	DESCRIPTION	BY	CKD. BY	WEIGHT POUNDS	VOLUME CUBIC FEET	FIGURE NUMBER
W	10-8-21	Added NOTE 1 & 2	KK	JM			2005
V	8-27-21	Edited Variations	KK	JM			
U	7-23-19	Added Load Rating	MW	JM			
T	6-14-19	Removed Function	MW	JM			
S	11-3-16	Revised Optional Materials	TBW	CL			

NOTE 1: Sediment Bucket -B not provided for a Hinged Grate (-H)

NOTE 2: Sediment Bucket -B not provided for a Ball Float (-BFV) or a Flapper Type (-V)

OPTIONAL STRAINER HEADS

ROUND STRAINER

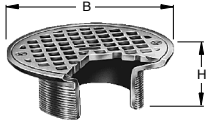

MATERIALS:
 Chrome Plated -CP
 Polished Bronze -PB
 Nickel Bronze -NB
 Stainless Steel
 Strainers -SS [Available in 05(125) & 06(150) sizes only]

VARIATIONS:
 *Hinged Grate (Specify Suffix -AH) (NOTE 1)
 Sediment Bucket -B
 Vandal Proof Screws -U

B DIA	05 (125)	06 (150)	07 (180)	08 (205)	09 (230)	10 (255)
H	2 (51)	2 (51)	2 1/4 (57)	2 1/2 (64)	2 1/2 (64)	2 3/4 (70)
X MIN	1 1/4 (32)	1 1/4 (32)	1 1/4 (32)	1 1/2 (38)	1 1/2 (38)	1 1/2 (38)
X MAX	2 1/4 (57)	2 1/4 (57)	2 1/4 (57)	2 1/2 (64)	2 1/2 (64)	2 3/4 (70)

LIGHT DUTY

SUFFIX -A

Specify Type, Size & Finish eg: A05NB
 *Not available for 05" (125) size

FLAPPER TYPE BACKWATER VALVE

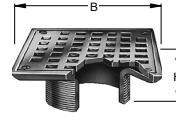

FUNCTION: Provides backwater protection at point where protection is needed.

MATERIALS:
 Chrome Plated -CP
 Polished Bronze -PB
 Nickel Bronze -NB

VARIATIONS:
 *Hinged Grate (Specify Suffix -AH)
 Vandal Proof Screws -U

B SQ	05 (125)	06 (150)	07 (180)	08 (205)
H	2 (51)	2 (51)	2 1/4 (57)	2 1/2 (64)
X MIN	1 1/4 (32)	1 1/4 (32)	1 1/4 (32)	1 1/2 (38)
X MAX	2 1/4 (57)	2 1/4 (57)	2 1/4 (57)	2 1/2 (64)

LIGHT DUTY

SUFFIX -AV

Specify Type, Size & Finish eg: AV05NB
 *Not available for 05" (125) size

SQUARE STRAINER

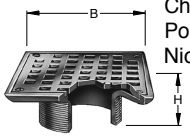

MATERIALS:
 Chrome Plated -CP
 Polished Bronze -PB
 Nickel Bronze -NB

VARIATIONS:
 Flapper Type Backwater Valve (Specify Suffix -BV) 05 (125), 06 (150), 07 (180) or 08" (205) sizes only (NOTE 2)
 *Hinged Grate (Specify Suffix -BH) (NOTE 1)
 Sediment Bucket -B
 Vandal Proof Screws -U

B SQ	05 (125)	06 (150)	07 (180)	08 (205)	09 (230)	10 (255)
H	2 (51)	2 (51)	2 1/4 (57)	2 1/2 (64)	2 1/4 (57)	2 1/4 (57)
X MIN	1 1/4 (32)	1 1/4 (32)	1 1/4 (32)	1 1/2 (38)	1 1/2 (38)	1 1/2 (38)
X MAX	2 1/4 (57)	2 1/4 (57)	2 1/4 (57)	2 1/2 (64)	2 1/4 (57)	2 3/8 (60)

LIGHT DUTY

SUFFIX -B

Specify Type, Size & Finish eg: B05NB
 *Not available for 05" (125) size

STRAINER HEAD w/SQUARE HINGED COVER

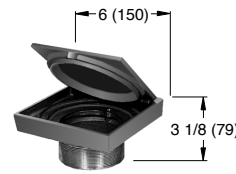

MATERIALS:
 Chrome Plated -CP
 Polished Bronze -PB
 Nickel Bronze -NB

VARIATIONS:
 Gasketed Water Tight Cover -GC
 Secured Cover -SC
 Secondary Strainer Grate-SG

LIGHT DUTY

SUFFIX -BS

Specify Type, Size & Finish eg: BSNB

REINFORCED ROUND STRAINER

FUNCTION: Used in finished floors where light wheeled loads are anticipated.

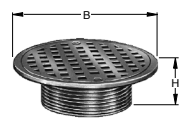

MATERIALS:
 Chrome Plated -CP
 Polished Bronze -PB
 Nickel Bronze -NB

VARIATIONS:
 Flapper Type Backwater Valve (Specify Suffix -CV) (NOTE 2)
 Sediment Bucket -B
 Vandal Proof Screws -U

B DIA	05 (125)	06 (150)	08 (205)	10 (255)
H	2 (51)	2 (51)	2 1/2 (64)	2 3/4 (70)
MIN	1 1/4 (32)	1 1/4 (32)	1 1/2 (38)	1 7/8 (48)
MAX	2 1/4 (57)	2 1/4 (57)	2 1/2 (64)	2 3/4 (70)

LIGHT DUTY

SUFFIX -C

Specify Type, Size & Finish eg: C06NB

REINFORCED TRACTOR STRAINER

FUNCTION: Used in finished floors where light weight wheeled loads are anticipated and loose set non-tilt tractor grate is desired.

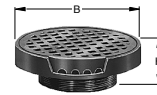

MATERIALS:
 Cast Iron -CI
 Chrome Plated -CP
 Polished Bronze -PB
 Nickel Bronze -NB

VARIATIONS:
 Flapper Type Backwater Valve (Specify Suffix -DV or -EV) (NOTE 2)
 Sediment Bucket -B
 Vandal Proof Screws -U

SUFFIX	B DIA	H	X	
			MIN	MAX
-D	07 (180)	3 1/4 (83)	2 5/8 (67)	3 1/2 (89)
-E	09 (230)	3 1/2 (89)	2 3/4 (70)	3 1/2 (89)

LIGHT DUTY

SUFFIX -D-E

Specify Type, Size & Finish eg: D07PB
 E09PB

TILE FLANGE

FUNCTION: Provides integral flange set 5/32"(4) below rim to receive floor covering. Flange may have option of tapped holes for securing pan and gasket.

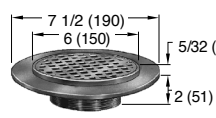

MATERIALS:
 Chrome Plated -CP
 Polished Bronze -PB
 Nickel Bronze -NB

VARIATIONS:
 Flapper Type Backwater Valve (Specify Suffix -FV) (NOTE 2)
 Holes in Flange -SH
 Sediment Bucket -B
 Vandal Proof Screws -U

X	
MIN	MAX
1 1/4 (32)	2 1/8 (54)

LIGHT DUTY

SUFFIX -F

Specify Type, Size & Finish eg: F06NB

ADJUSTABLE STRAINER HEAD

FUNCTION: Used in a non-traffic area when a funnel type strainer head is required and space does not allow use of the 3500 series funnel. The extended rim allows use as an anti-flood and anti-splash drip pan.

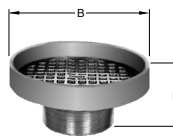

VARIATIONS:
 Flapper Type Backwater Valve (Specify Suffix -F37V or F38V)

MATERIALS:
 Cast Iron -CI
 Chrome Plated -CP
 Galvanized Cast Iron -G
 Polished Bronze -PB
 Nickel Bronze -NB

SUFFIX	-F37	-F38
B DIA	07 (180)	09 (230)
H	3 1/4 (83)	3 1/2 (89)
X MIN	2 5/8 (67)	2 3/4 (70)
X MAX	3 1/2 (89)	3 1/2 (89)

NON-TRAFFIC

SUFFIX -F37-F38

Specify Type, Size & Finish eg: F37NB F38CP

DRAWING NUMBER
PM0457 SH 1 of 2

SIZE
A

SCALE
NONE

DATE:
5-17-85

APPROVED BY:
TD

CHECKED BY:
TD

DRAWN BY:
PJ

2010 SERIES OPTIONAL STRAINER HEADS

FIGURE NUMBER

REV.	DATE	DESCRIPTION	BY	CKD. BY
M	10-8-21	Added NOTE 1 & 2	KK	JM
L	10-26-20	Rev. Finish (Tractor Stainer)	MW	CL
K	7-29-19	Added Load Rating(s)	MW	JM

FIGURE NUMBER
2010 SERIES OPTIONAL STRAINER HEADS
1 of 2

NOTE: Dimensions shown in parentheses are in millimeters.



WARNING: Cancer and Reproductive Harm - www.P65Warnings.ca.gov

OPTIONAL STRAINER HEADS

LOW DOME STRAINER

FUNCTION: Used in gutters and recessed areas where excessive debris build-up is expected. Dome insures drainage even when partly covered.

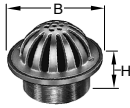

MATERIALS:
 Chrome Plated -CP
 Polished Bronze -PB
 Nickel Bronze -NB

VARIATIONS:
 Flapper Type Backwater Valve (Specify Suffix -GV)
 Sediment Bucket -B
 Vandal Proof Screws -U

B DIA	05 (125)	06 (150)	08 (205)
H	2 (51)	2 (51)	2 1/2 (64)
MIN	1 1/4 (32)	1 1/4 (32)	1 1/2 (38)
MAX	2 1/4 (57)	2 1/4 (57)	2 1/2 (64)

NON-TRAFFIC
SUFFIX -G Specify Type, Size & Finish eg: G08PB

SOLID HINGED COVER

FUNCTION: Used in areas where intermittent drain use is required. Solid cover prevents intrusion of chips, saw-dust, etc., which are swept up before cover is opened for washdown. The secondary strainer prevents debris from entering the waste line.

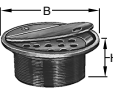

MATERIALS:
 Chrome Plated -CP
 Polished Bronze -PB
 Nickel Bronze -NB

VARIATIONS:
 Flapper Type Backwater Valve (Specify Suffix -GV)
 Vandal Proof Screws -U

B DIA	05 (125)	06 (150)	07 (180)	08 (205)
H	2 (51)	2 (51)	2 1/4 (57)	2 1/2 (64)
X MIN	1 1/4 (32)	1 1/4 (32)	1 1/4 (32)	1 1/2 (38)
X MAX	2 1/4 (57)	2 1/4 (57)	2 1/4 (57)	2 1/2 (64)

LIGHT DUTY
SUFFIX -H Specify Type, Size & Finish eg: H05CP

SPANNER WRENCH COVER

FUNCTION: Solid gas tight, vandal proof, threaded cover for areas where intermittent drain use is required.

MATERIALS:
 Chrome Plated -CP
 Polished Bronze -PB
 Nickel Bronze -NB

VARIATIONS:
 Flapper Type Backwater Valve (Specify Suffix -JV)
 Sediment Bucket -B

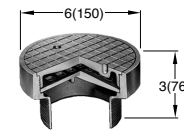

MEDIUM DUTY	
X	
MIN	2 (51)
MAX	3 (76)

SUFFIX -J Specify Type, Size & Finish eg: J06NB

REINFORCED SQUARE STRAINER

FUNCTION: Used in finished floors where some light wheeled traffic is anticipated.

MATERIALS:
 Chrome Plated -CP
 Polished Bronze -PB
 Nickel Bronze -NB

VARIATIONS:
 Flapper Type Backwater Valve (Specify Suffix -KV)
 Sediment Bucket -B
 Vandal Proof Screws -U

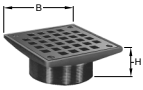

B SQ	05 (125)	06 (150)	07 (180)	08 (205)
H	2 (51)	2 (51)	2 1/4 (57)	2 1/2 (64)
X MIN	1 1/4 (32)	1 1/4 (32)	1 1/4 (32)	1 1/2 (38)
X MAX	2 1/4 (57)	2 1/4 (57)	2 1/4 (57)	2 1/2 (64)

LIGHT DUTY
SUFFIX -K Specify Type, Size & Finish eg: K07CP

RECTANGULAR STRAINER

FUNCTION: Used in finished floors where light wheeled loads and or heavy foot traffic are anticipated.

MATERIALS:
 Chrome Plated -CP
 Polished Bronze -PB
 Nickel Bronze -NB

VARIATIONS:
 Sediment Bucket -B
 Vandal Proof Screws -U

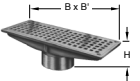

SUFFIX	L	M	N	P	R	T
B x B'	4 1/2(115)x8(205)	4(100)x12(305)	5(125)x9(230)	5(125)x13(330)	6(150)x10(255)	5(125)x17(430)
H	2 1/4 (57)	2 1/2 (64)	2 1/4 (57)	3 (76)	2 1/4 (57)	3 (76)
X MIN	1 3/8 (35)	1 7/8 (48)	1 3/8 (35)	2 1/8 (54)	1 3/8 (35)	2 1/4 (57)
X MAX	2 3/8 (60)	2 3/4 (70)	2 3/8 (60)	3 (76)	2 3/8 (60)	3 1/8 (79)

LIGHT DUTY
SUFFIX -L-M-N-P-R-T Specify Type, Size & Finish eg: LNB

ANGLE STRAINER

FUNCTION: Shower room drain set at wall and floor junction. Vertical grate openings prevent drain stoppage should flat surface become covered.

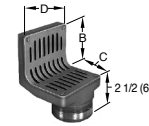

MATERIALS:
 Chrome Plated -CP
 Polished Bronze -PB
 Nickel Bronze -NB

VARIATIONS:
 Vandal Proof Screws -U

SUFFIX	B	C	D	X	
				MIN	MAX
-V	3 1/2 (89)	3 1/2 (89)	4 1/2 (115)	1 5/8 (41)	2 5/8 (67)
-W	6 3/4 (170)	6 3/4 (170)	6 1/2 (165)	1 5/8 (41)	2 5/8 (67)

LIGHT DUTY
SUFFIX -V -W Specify Type, Size & Finish eg: VPB, WNB

EXTENSION ADAPTOR

FUNCTION: Used when a strainer head must be raised to accommodate deeper floor fill.

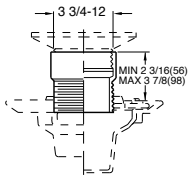

REGULARLY FURNISHED:
 Duco Cast Iron -CI

MATERIALS:
 Cast Bronze -CB
 Galvanized Cast Iron -G

NOTE: Extension can be stacked for increased maximum adjustment.

SUFFIX -X

OVERFLOW WITH STANDPIPE

FUNCTION: Used as overflow drain in decorative pools, fish ponds or similar areas. Dome prevents floating objects from entering drain line.

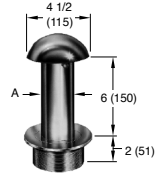

SUFFIX	A	X	
	SIZE	MIN	MAX
-Y	2 (51)	3/4 (19)	2 1/8 (54)
-Z	3 (76)	3/4 (19)	2 1/8 (54)

SUFFIX -Y-Z Specify Type, Size & Finish eg: YCP, ZCP

MATERIALS:
 Chrome Plated -CP
 Nickel Bronze -NB
 Polished Bronze -PB

VARIATIONS:
 Less Dome -LD
 Standpipe Height other than 6" (150) (Specify Height)

FUNCTION: Used in finished floors where light wheeled loads and or heavy foot traffic are anticipated.

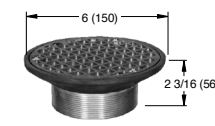

MATERIALS:
 Polished Bronze -PB
 Rough Bronze -RB
 Nickel Bronze -NB

VARIATIONS:
 Flapper Type Backwater Valve (Specify Suffix -69V)
 Sediment Bucket -B
 Vandal Proof Screws -U

MEDIUM DUTY
SUFFIX -69 eg: A06NB-69

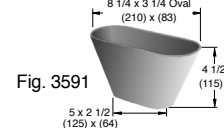
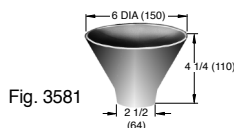

L	7-29-19	Added Load Rating(s) Rev. Materials Suffix -H, -V-W Rev. Variations of Suffix -J Revised Revised Tables	MW	JM	FIGURE NUMBER 2010 SERIES OPTIONAL STRAINER HEADS 2 of 2
K	10-20-17		TBW	CL	
J	1-17-12		TBW	AM	
H	8-24-99		TBW	BS	
G	6-11-99		CMD		
REV.	DATE	DESCRIPTION	BY	CKD. BY	



DRAWING NUMBER
PM0457 SH 2 of 2

SIZE
A

SCALE
NONE

DATE:
5-17-85

APPROVED BY:
TD

CHECKED BY:
TD

DRAWN BY:
PJ

2010 SERIES OPTIONAL
STRAINER HEADS

FIGURE
NUMBER

ASSUME NO RESPONSIBILITY OR USE OF SUPERSEDED OR VOID DATA

DIMENSIONS ARE SUBJECT TO MANUFACTURERS TOLERANCE AND CHANGE WITHOUT NOTICE