

E



JAY R. SMITH MFG. CO.®
 MEMBER OF MORRIS GROUP INTERNATIONAL
 POST OFFICE BOX 3237
 MONTGOMERY, ALABAMA 36109-0237 (USA)
 TEL: 334-277-8520 FAX: 888-377-7818 www.jrsmith.com



MEMBER OF:

LOCATION

DRAWING NUMBER
s1909SIZE
ASCALE:
NONEDATE:
5-7-08APPROVED BY:
CLCHECKED BY:
CLDRAWN BY:
RN

WE CAN ASSUME NO RESPONSIBILITY FOR USE OF SUPERSEDED OR VOID DATA

DIMENSIONS ARE SUBJECT TO MANUFACTURERS TOLERANCE AND CHANGE WITHOUT NOTICE

PLANTING AREA DRAINS

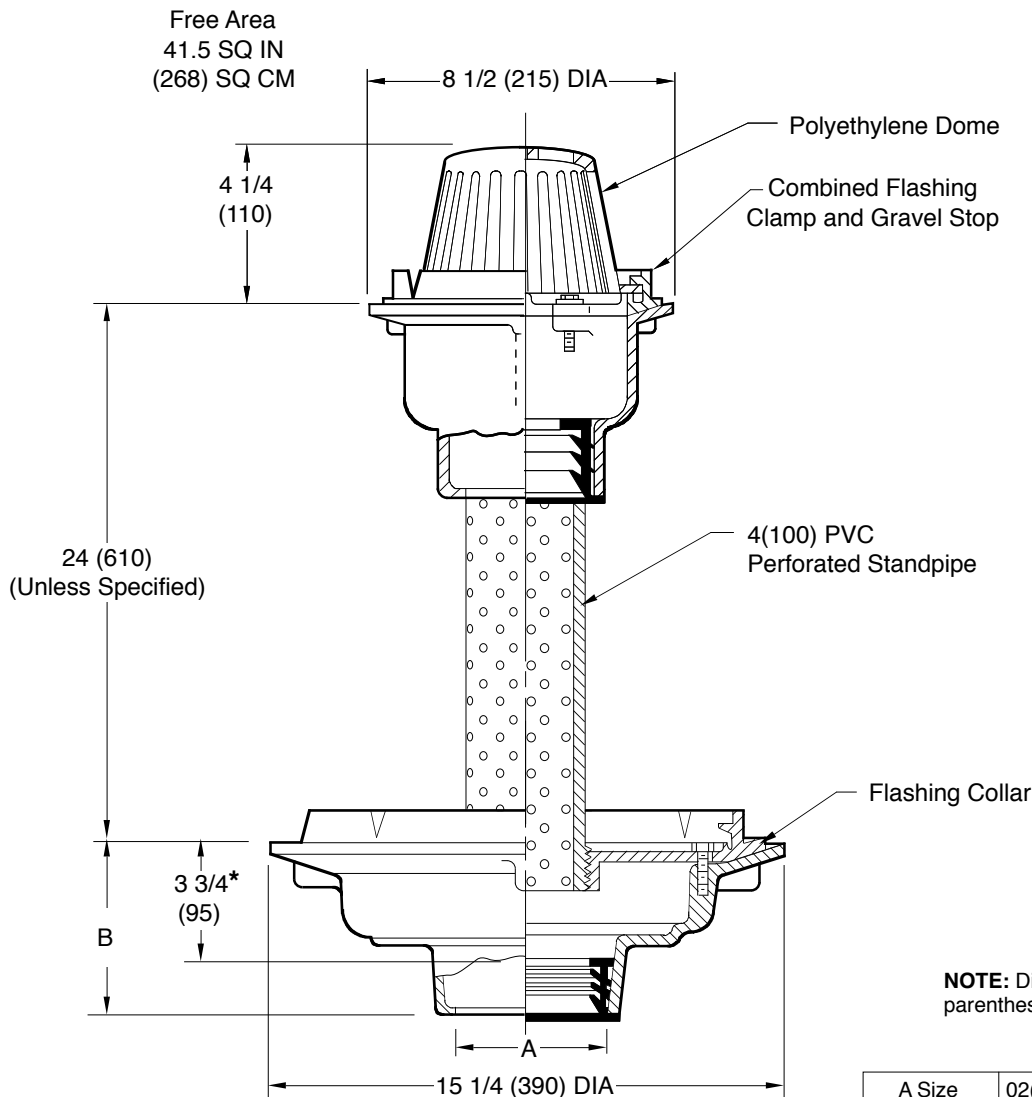

NOTE: Dimensions shown in parentheses are in millimeters.

*This Dimension to Internal Stop of Speedi-Set Gasket.

Fig. 1909C CAULK OUTLET
 Fig. 1909Y NO-HUB OUTLET

A Size	02(50)	03(75)	04(100)
B	5(125) for Caulk, No-Hub and Speedi-Set 3 3/4(95) for Threaded		

REGULARLY FURNISHED:

Duco Cast Iron Lower Body and Flashing Collar with 4(100) PVC Perforated Standpipe and Duco Cast Iron Upper Body with Combined Flashing Clamp and Gravel Stop with Polyethylene Dome.

VARIATIONS:

L Speedi-Set Service Weight
 LXH Speedi-Set Extra Heavy
 Solid Standpipe -SP
 Standpipe Covered with Stainless Steel Mesh -SSM
 with Seepage Holes in Flashing Collar - WSH

OPTIONAL MATERIALS:

Aluminum Dome -AD
 Cast Iron Dome -CID
 Galvanized Cast Iron Body & Collar -G
 Galvanized Cast Iron Dome -CIDG
 Rough Bronze Dome -RBD

1909

E 6-22-21
 D 8-7-12
 C 04/19/10
 B 03/25/10

Added Option Under Variations
 Rev. Optional Materials
 Added 24 unless specified
 Removed SQ note

KK
 TBW
 JJ
 JJ

CL
 CL
 TK
 TK

WEIGHT
POUNDSVOLUME
CUBIC FEET

FIGURE NUMBER

1909

REV.	DATE	DESCRIPTION	BY	CKD. BY



WARNING: Cancer and Reproductive Harm - www.P65Warnings.ca.gov