

# SIPHONIC GUTTER DRAIN

## 6"(150) DIAMETER - LOW PROFILE GUTTER DRAIN

**FUNCTION:** For use in engineered siphonic roof drainage systems for gutters, parapets, small balconies, sills, cornices, marquees and other small overhanging areas where drainage of rainwater is required. Air baffle creates siphonic drainage action producing more efficient drainage than traditional gutter drains.

Free Area  
 5.42 Sq. In.  
 (35) Sq. Cm.

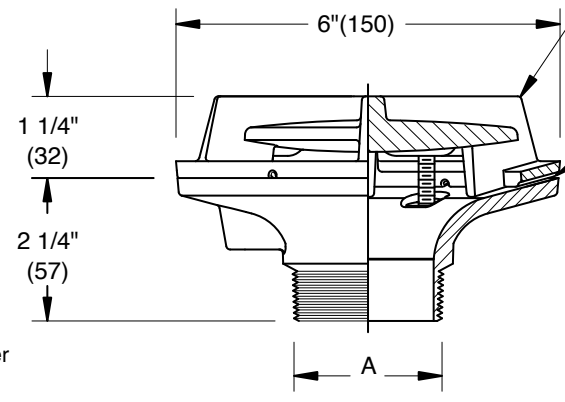
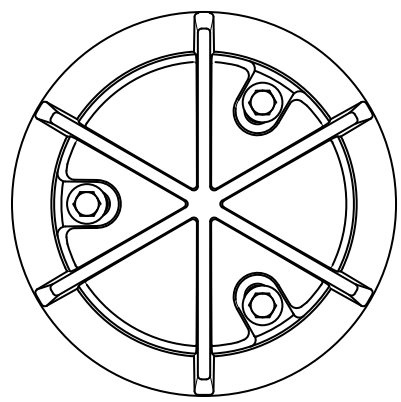

Combination Flashing  
 Clamp and Air Baffle

Seepage Openings

A(Pipe Size) = 02(50)

- NOTES:**
1. Drain shall be installed per local code requirements
  2. Dimensions shown in parentheses are in millimeters.

| Performance Data * |                           |                        |
|--------------------|---------------------------|------------------------|
| Size (A)<br>in(mm) | Max Capacity<br>cfs (lps) | Resistance<br>Value, K |
| 02 (50)            | 0.40 (11.3)               | 0.66                   |

- Fig. 1605T ..... MALE THREADED OUTLET
- Fig. 1605Y ..... NO HUB OUTLET

**REGULARLY FURNISHED:**  
 Duco Cast Iron Body with  
 Combination Flashing Clamp and  
 Air Baffle.

**VARIATIONS:**  
 Vandal Proof -U

**OPTIONAL MATERIALS:**  
 Galvanized Cast Iron -G

\*As tested and certified by ANSI/ASME A112.6.9 "Siphonic Roof Drains" procedures and test apparatus.  
 IAPMO Listed File No. 5138

U.S. Patent No. D576,257S

DRAWING NUMBER: S1605  
 SIZE: A  
 SCALE: NONE  
 DATE: 4-14-06  
 APPROVED BY: CR  
 CHECKED BY: CR  
 DRAWN BY: RN  
 DIMENSIONS ARE SUBJECT TO MANUFACTURERS TOLERANCE AND CHANGE WITHOUT NOTICE  
 WE CAN ASSUME NO RESPONSIBILITY FOR USE OF SUPERSEDED OR VOID DATA

|          |          |                  |            |           |
|----------|----------|------------------|------------|-----------|
| <b>C</b> | 10-10-08 | Added Patent No. | <b>RN</b>  | <b>CL</b> |
| <b>B</b> | 5-21-07  | Added Notes      | <b>RN</b>  | <b>CL</b> |
| <b>A</b> | 5-10-06  | Added Notes      | <b>TBW</b> | <b>CL</b> |
| REV.     | DATE     | DESCRIPTION      | BY         | CKD. BY   |

|                  |                      |                      |
|------------------|----------------------|----------------------|
| WEIGHT<br>POUNDS | VOLUME<br>CUBIC FEET | <b>FIGURE NUMBER</b> |
|                  |                      | <b>1605</b>          |