

M

SMITH® JAY R. SMITH MFG. CO.®
 MEMBER OF MORRIS GROUP INTERNATIONAL
 POST OFFICE BOX 3237
 MONTGOMERY, ALABAMA 36109-0237 (USA)
 TEL: 334-277-8520 FAX: 888-377-7818 www.jrsmith.com



MEMBER OF:

LOCATION

PROMENADE DECK DRAIN FOR INSULATED ROOF DECKS

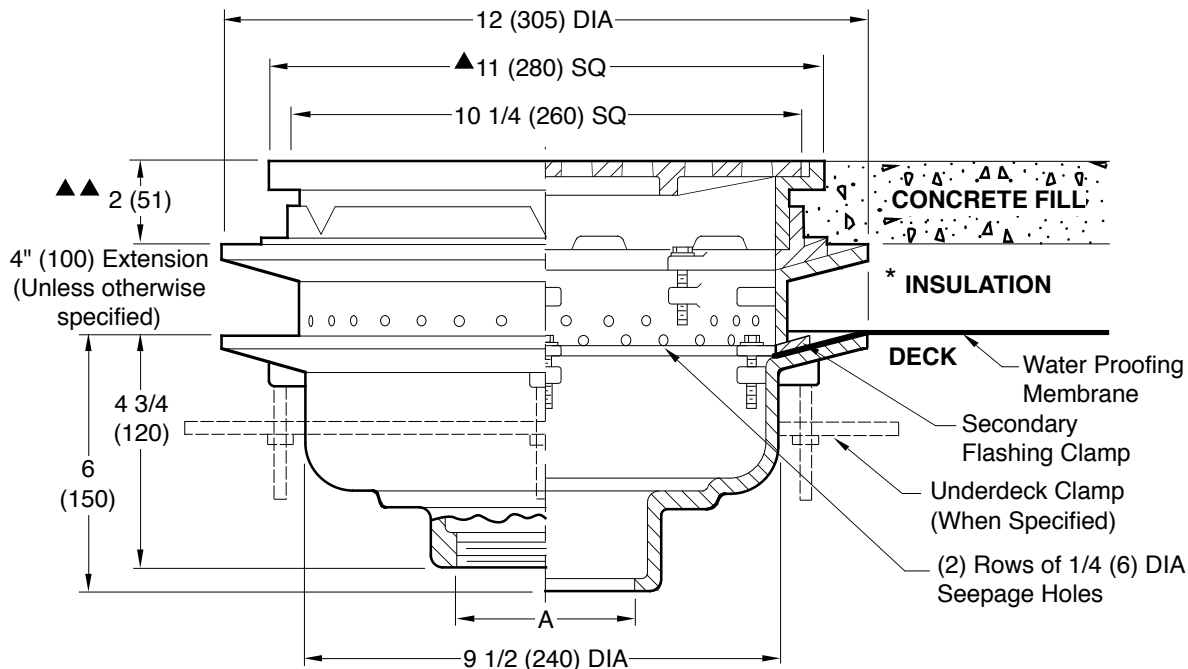

A (Pipe Size) = 02(50),03(75),04(100),05(125) & 06(150)

Fig. 1459C CAULK OUTLET
 Fig. 1459Y NO-HUB OUTLET
 Fig. 1459T THREADED OUTLET

- ▲ Add 1/4"(6) when bronze top is specified.
 ▲▲ Add 1/8"(3) when bronze top is specified.

recommended deck opening

with suffix -R	13 (330) DIA
less suffix -R	11 (280) DIA

REGULARLY FURNISHED:

Duco Cast Iron Body and 4" (100) Extension with Secondary Flashing Clamp and Seepage Openings with Secured Square Hole Grate.

VARIATIONS:

- Expansion Joint (Specify Fig. 1710)
 Extension (Specify Height) -E
 "L" Shaped Underdeck Clamp -CL
 L Speedi-Set Service Weight
 02(50), 03(75) & 04"(100) sizes only
 LXH Speedi-Set Extra Heavy
 02(50), 03(75) & 04"(100) sizes only
 Sump Receiver -R
 Underdeck Clamp -C
 Vandal Proof Grate -U
 S.S. Perforated Extension

OPTIONAL MATERIALS:

- Ductile Iron Grate -M
 Galvanized Cast Iron -G
 Nickel Bronze Top -NB
 Polished Bronze Top -PB

* On some systems this layer includes a layer of pea gravel and a layer of insulation.

NOTE: Dimensions shown in parentheses are in millimeters.

DRAWING NUMBER
S1459SIZE
ASCALE:
NONEDATE:
2-2-82APPROVED BY:
JMCHECKED BY:
JMDRAWN BY:
KGFIGURE NUMBER
1459WE CAN ASSUME NO RESPONSIBILITY FOR USE OF SUPERSEDED OR VOID DATA
DIMENSIONS ARE SUBJECT TO MANUFACTURERS TOLERANCE AND CHANGE WITHOUT NOTICE

M	7-21-21	Added Fig. # 1459T	KK	CL
L	8-11-14	Revised Drawing	TBW	CL
K	7-18-00	Revised Variations	TBW	BW
J	6-16-99	Revised millimeters	CMD	BS

W	CL
CL	CL
TBW	BW
CMD	BS

WEIGHT
POUNDSVOLUME
CUBIC FEET

FIGURE NUMBER

1459

REV.	DATE	DESCRIPTION	BY	CKD. BY
------	------	-------------	----	---------



WARNING: Cancer and Reproductive Harm - www.P65Warnings.ca.gov