

B

**SMITH® JAY R. SMITH MFG. CO.®**  
 MEMBER OF MORRIS GROUP INTERNATIONAL  
 POST OFFICE BOX 3237  
 MONTGOMERY, ALABAMA 36109-0237 (USA)  
 TEL: 334-277-8520 FAX: 334-272-7396 www.jrsmith.com



MEMBER OF:

LOCATION

DRAWING NUMBER  
S1070 (-E-W)

SIZE  
A

SCALE:  
NONE

DATE:  
02/12/08

APPROVED BY:  
CL

CHECKED BY:  
CL

DRAWN BY:  
JJ

1070 (-E-W)

WE CAN ASSUME NO RESPONSIBILITY FOR USE OF SUPERSEDED OR VOID DATA

DIMENSIONS ARE SUBJECT TO MANUFACTURERS TOLERANCE AND CHANGE WITHOUT NOTICE

# LARGE SPECIAL PURPOSE ROOF DRAINS

## WITH OVERFLOW STANDPIPE

Free Area  
102.5 SQ IN  
(661) SQ CM

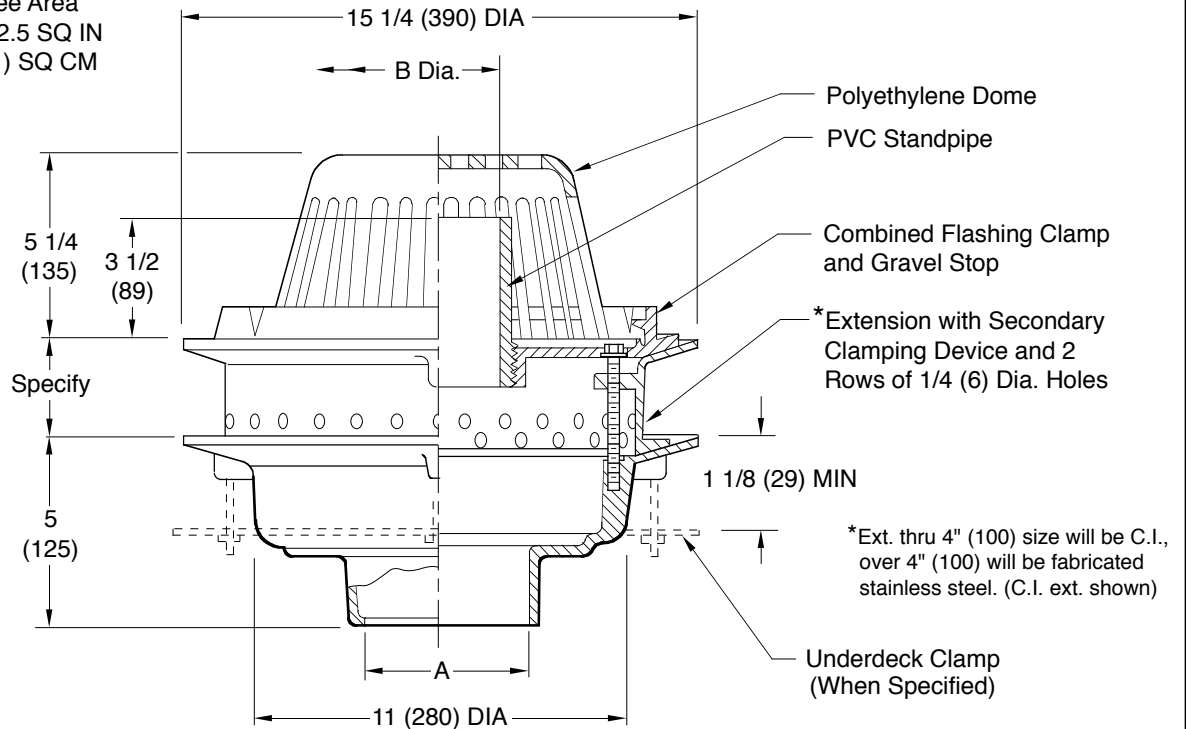

A (Pipe Size)	02 (50)	03 (75)	04 (100)	05 (125)	06 (150)	08 (200)
B (DIA)	4 (100)	4 (100)	4 (100)	6 (150)	6 (150)	8 (200)

Fig. 1070C (-E-W) . . . . . CAULK OUTLET  
 Fig. 1070Y (-E-W) . . . . . NO-HUB OUTLET

recommended deck opening	
with suffix -R	17 (430) DIA
less suffix -R	14 (355) DIA

**REGULARLY FURNISHED:**  
 Duco Cast Iron Body, Extension with Secondary Clamping Device and 2 Rows of 1/4 (6) Dia. Holes, P.V.C. Standpipe, Combined Flashing Clamp and Gravel Stop and Polyethylene Dome.

**VARIATIONS:**

- Vandal Proof Dome -U
- Sump Receiver -R
- Underdeck Clamp -C
- T Threaded Outlet

**OPTIONAL MATERIALS:**

- Aluminum Dome -AD
- Cast Iron Dome -CID
- Galvanized Cast Iron -G
- Rough Bronze Dome -RBD
- Cast Iron Standpipe -CIS

**NOTE:** Dimensions shown in parentheses are in millimeters.

REV.	DATE	DESCRIPTION	BY	CKD. BY	WEIGHT POUNDS	VOLUME CUBIC FEET
B	7-30-19	Removed NOTE	MW	CL		
A	10-8-15	Added Flow Rate Note	TBW	BW		

**FIGURE NUMBER**  
**1070 (-E-W)**