

H

SMITH® JAY R. SMITH MFG. CO.®
 MEMBER OF MORRIS GROUP INTERNATIONAL
 POST OFFICE BOX 3237
 MONTGOMERY, ALABAMA 36109-0237 (USA)
 TEL: 334-277-8520 FAX: 334-272-7396 www.jrsmith.com



MEMBER OF:

LOCATION

ROOF DRAINS SPECIAL ROOF APPLICATIONS

FUNCTION: Used on roof systems where the insulated membrane assembly method of waterproofing is installed using a liquid membrane. The adjustable extension sleeve permits adjustment from a min of 1 1/4 (32) to a max of 4 (100) easily accommodating 2 3/4"(70) of varying insulation thicknesses. The positive threading allows smooth perimeter movement and circumferential support of the top at any adjusted elevation. A perforated stainless steel extension is supplied to retain the crushed gravel used in flat roof construction.

Free Area
 102.5 SQ IN
 (661) SQ CM

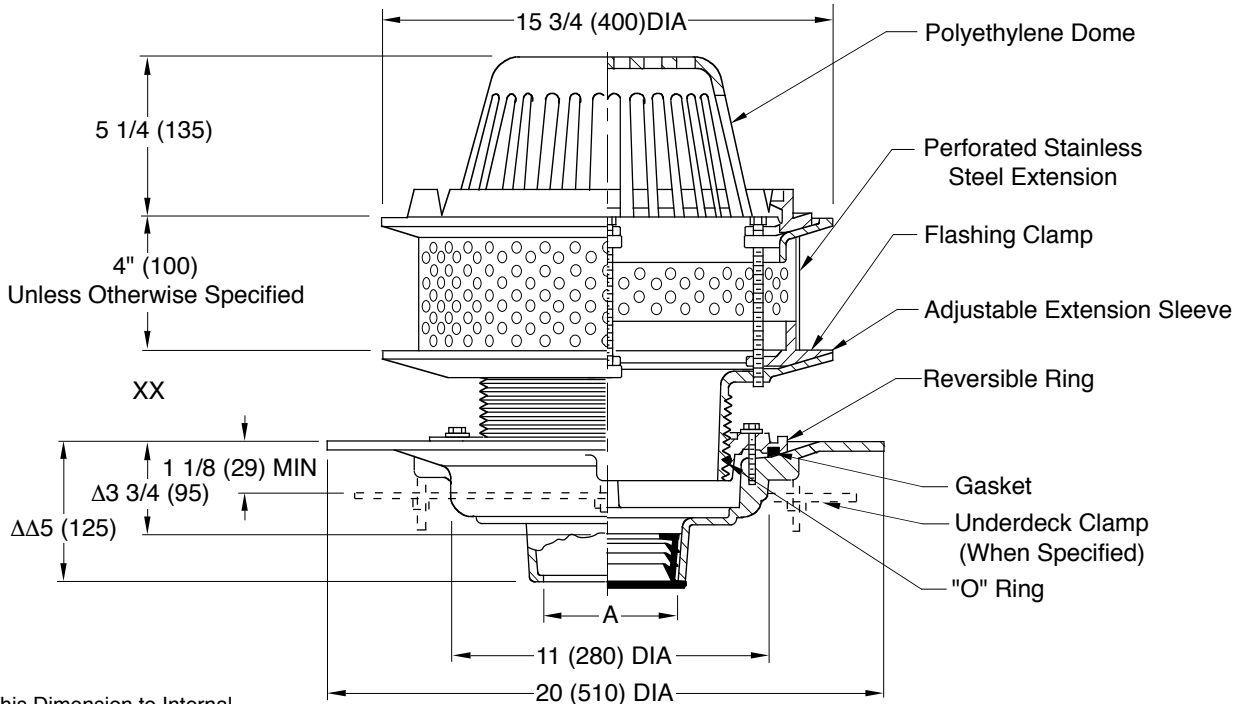

Δ This Dimension to Internal Stop of Speedi-Set Gasket.
 ΔΔ Same for caulk, NO-HUB and Speedi-Set, 3 3/4 (95) for Threaded.
NOTE: Dimensions shown in parentheses are in millimeters.
NOTE: Recommended deck opening 14 3/4" (375).

A (Pipe Size) = 02(50), 03(75), 04(100), 05(125) or 06(150)

- Fig. 1038C CAULK OUTLET
- Fig. 1038Y..... NO-HUB OUTLET

	XX	MIN	MAX
Low Position	1 1/4 (32)	2 1/2 (64)	
High Position	2 1/4 (57)	4 (100)	

REGULARLY FURNISHED:

Duco Cast Iron Body with Adjustable Extension Sleeve, Perforated Stainless Steel Extension, Combined Flashing Clamp and Gravel Stop, and Polyethylene Dome

VARIATIONS:

- Expansion Joint (Specify Fig. 1710) (Fig. 1010 only)
- Higher Gravel Stop (Specify Height) -HGS
- "L" Shaped Underdeck Clamp -CL
- "L" Speedi-Set Service Weight 02(50), 03(75), and 04"(100) sizes only (Fig. 1010 only)
- LXH Speedi-Set Extra Heavy 02(50), 03(75), and 04"(100) sizes only (Fig. 1010 only)
- Sump Receiver -R
- Underdeck Clamp -C
- Vandal Proof Dome -U
- T Threaded Outlet

OPTIONAL MATERIALS:

- ▲ Aluminum Dome -AD
- ▲ Cast Iron Dome -CID
- Galvanized Cast Iron -G
- ▲ Rough Bronze Dome -RBD

▲ **Optional domes' free area are as follows:**
 Aluminum 98 (632)
 Cast Iron 80 (516)
 Bronze 95 (613)

DRAWING NUMBER
S1038

SIZE
A

SCALE:
NONE

DATE:
10-8-87

APPROVED BY:
CR

CHECKED BY:
BS

DRAWN BY:
EMB

1038

FIGURE NUMBER

H G F E	7-30-19 4-14-16 9-17-15 06/04/09	Removed NOTE Revised Text Added Flow Rate Note Added Optional Dome Notes
REV.	DATE	DESCRIPTION

MW TBW TBW JJ	CL CL BW CL
BY	CKD. BY

WEIGHT POUNDS	VOLUME CUBIC FEET
------------------	----------------------

FIGURE NUMBER
1038



WARNING: Cancer and Reproductive Harm - www.P65Warnings.ca.gov

WE CAN ASSUME NO RESPONSIBILITY FOR USE OF SUPERSEDED OR VOID DATA

DIMENSIONS ARE SUBJECT TO MANUFACTURERS TOLERANCE AND CHANGE WITHOUT NOTICE