

G
 DRAWING NUMBER S1010-83
 SIZE A
 SCALE: NONE
 DATE: 04/23/03
 APPROVED BY: BW
 CHECKED BY: BW
 DRAWN BY: JJ
 1010-83
 FIGURE NUMBER

SMITH® JAY R. SMITH MFG. CO.®
 MEMBER OF MORRIS GROUP INTERNATIONAL
 POST OFFICE BOX 3237
 MONTGOMERY, ALABAMA 36109-0237 (USA)
 TEL: 334-277-8520 FAX: 334-272-7396 www.jrsmith.com

CUSTOMER DRIVEN SINCE 1926

MEMBER OF:

LOCATION

FLOW REGULATING ROOF DRAIN

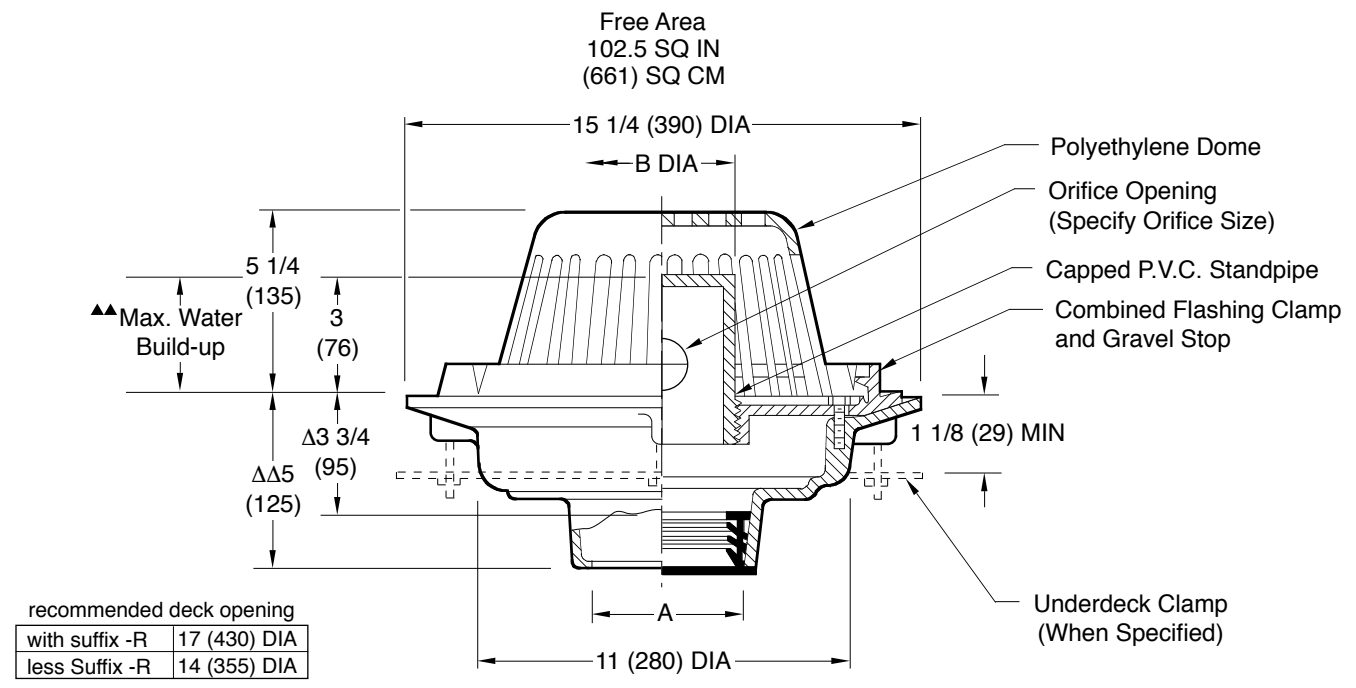

Δ This Dimension to Internal Stop of Speedi-Set Gasket.
 ΔΔ Same for Caulk, NO-HUB and Speedi-Set. 3 3/4 (95) for Threaded.

A(Pipe Size)	02(50)	03(75)	04(100)	05(125)	06(150)
B (DIA)	4(100)	4(100)	4(100)	6(150)	6(150)

- Fig. 1010-83C CAULK OUTLET
- Fig. 1010-83Y NO-HUB OUTLET

Orifice Size	Max. Build-Up (inches)	Flow Rate GPM

▲▲ Note: Engineer of record must provide flow rate information and max water build-up on roof and/or recommended orifice size.

REGULARLY FURNISHED:
 Duco Cast Iron Body, Flashing Clamp and Gravel Stop with P.V.C. Standpipe with Flow Control Orifice as Specified and Polyethylene Dome.

- VARIATIONS:**
- Expansion Joint (Specify Fig. 1710)
 - Extension (Specify Height) -E
 - E02 2" (51)
 - E04 4" (100)
 - E06 6" (150)
 - "L" Shaped Underdeck Clamp -CL
 - L Speedi-Set Service Weight
02(50), 03(75) & 04(100) sizes only
 - LXH Speedi-Set Extra Heavy
02(50), 03(75) & 04(100) sizes only
 - Secondary Flashing Clamp -C2
 - Sump Receiver -R
 - Underdeck Clamp -C
 - Vandal Proof Dome -U
 - T Threaded Outlet

- OPTIONAL MATERIALS:**
- Bronze Standpipe -BZS
 - Cast Iron Standpipe -CIS
 - Galvanized Cast Iron Body and Collar -G
 - ▲ Galvanized Cast Iron Dome -CIDG
 - ▲ Cast Iron Dome -CID
 - ▲ Aluminum Dome -AD
 - ▲ Rough Bronze Dome -RBD

NOTE: Dimensions shown in parentheses are in millimeters.

▲ Optional domes' free area are as follows:
 Aluminum 98 (632)
 Cast Iron 80 (516)
 Bronze 95 (613)

Patent No. 9,518,389

REV.	DATE	DESCRIPTION	BY	CKD. BY	WEIGHT POUNDS	VOLUME CUBIC FEET
G	8-15-17	Added Max Water Build-up	TBW	AM		
F	1-18-17	Revised Title	TBW	SJM		
E	9-16-15	Added Table, Patent Pending	TBW	CL		
D	4-20-12	Revised Drawing	TBW	CL		

FIGURE NUMBER
1010-83