

LABOR SAVER® HEAVY DUTY FIXTURE SUPPORT

FLOOR MOUNTED FOR SURGICAL SCRUB UP & FLUSHING RIM SINK

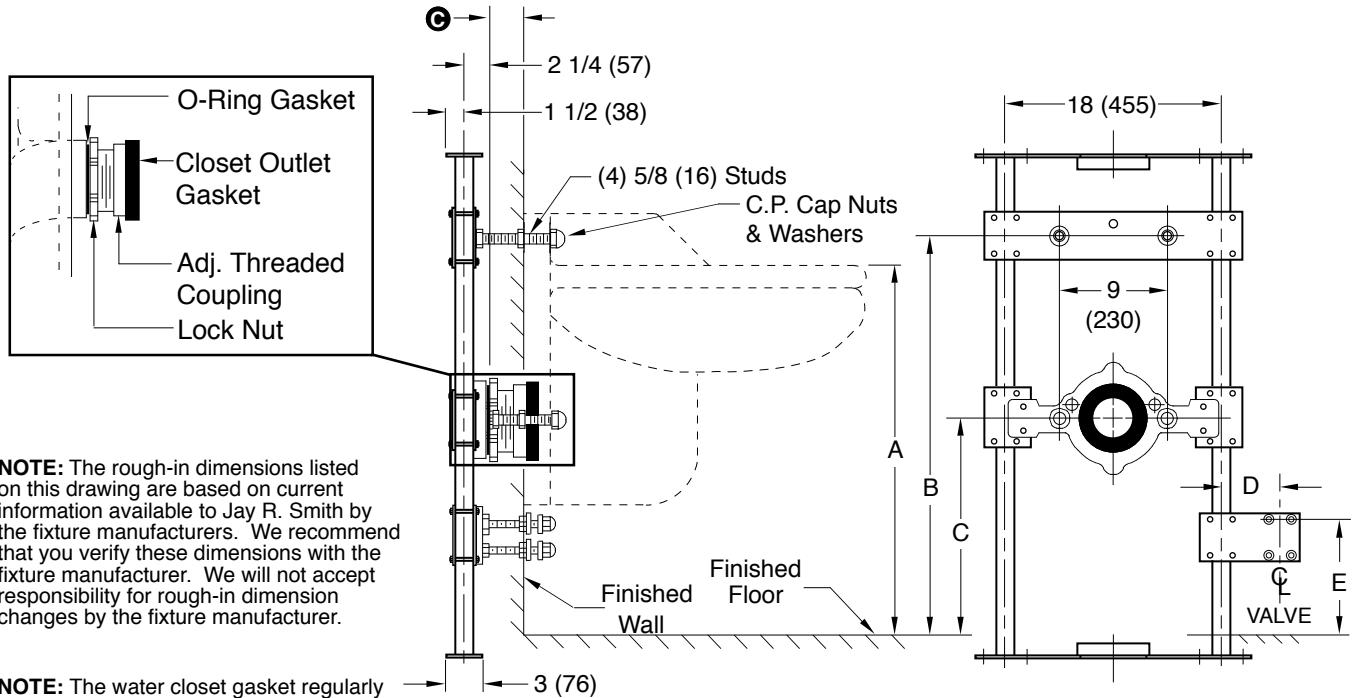

NOTE: The rough-in dimensions listed on this drawing are based on current information available to Jay R. Smith by the fixture manufacturers. We recommend that you verify these dimensions with the fixture manufacturer. We will not accept responsibility for rough-in dimension changes by the fixture manufacturer.

NOTE: The water closet gasket regularly furnished is made of molded neoprene and designed to fit water closet outlet dimensions and configurations shown in ANSI Standard A112.19.2M-1982, Figure 13B. If gasket is not found to be compatible to fixture due to nonconformance of said fixture to ANSI A112.19.2M, then fixture manufacturer shall be consulted for a suitable gasket recommendation. Jay R. Smith assumes no liability for connections to fixtures which do not conform to these standards.

NOTE: Dimensions shown in parenthesis are in millimeters.

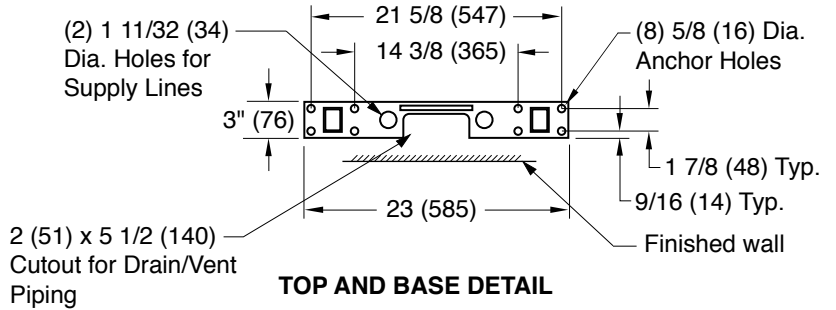

Fig. 0923..... 3" (80) OUTLET CONNECTION
 Fig. 0924..... 4" (100) OUTLET CONNECTION
 Fig. 0923 & 0924... WITH SUPPORTING STUD AND ADJUSTABLE COUPLING FOR BACK OUTLET FLUSHING RIM SERVICE SINK

FIG	SIZE	⊙ MIN	⊙ MAX
0923	3" (80)	2 3/4 (70)	4 3/4 (120)
0924	4" (100)	1 (25)	3 (76)

ROUGH-IN TABLE

FIXTURE MFG.	NAME	NUMBER	SIZE	A	B	C	D	E

⊙ This Dimension Can be Increased When Fixture Support is to be Installed Behind the Wall (Specify When Required and Wall Thickness).

REV.	DATE	DESCRIPTION	BY	CKD. BY	WEIGHT POUNDS	VOLUME CUBIC FEET	FIGURE NUMBER

0923, 0924 (-KW)

C
 DRAWING NUMBER S0923, 0924 (-KW)
 SIZE A
 SCALE: NONE
 DATE: 05/28/02
 APPROVED BY:
 CHECKED BY:
 DRAWN BY: JJ
 FIGURE NUMBER 0923, 0924 (-KW)
 DIMENSIONS ARE SUBJECT TO MANUFACTURERS TOLERANCE AND CHANGE WITHOUT NOTICE
 WE CAN ASSUME NO RESPONSIBILITY FOR USE OF SUPERSEDED OR VOID DATA