

LABOR SAVER® LAVATORY SUPPORTS WITH ENAMELED EXPOSED ARMS FOR HIGH BACK LAVATORIES WITH EXTENDED LUGS

FLOOR MOUNTED

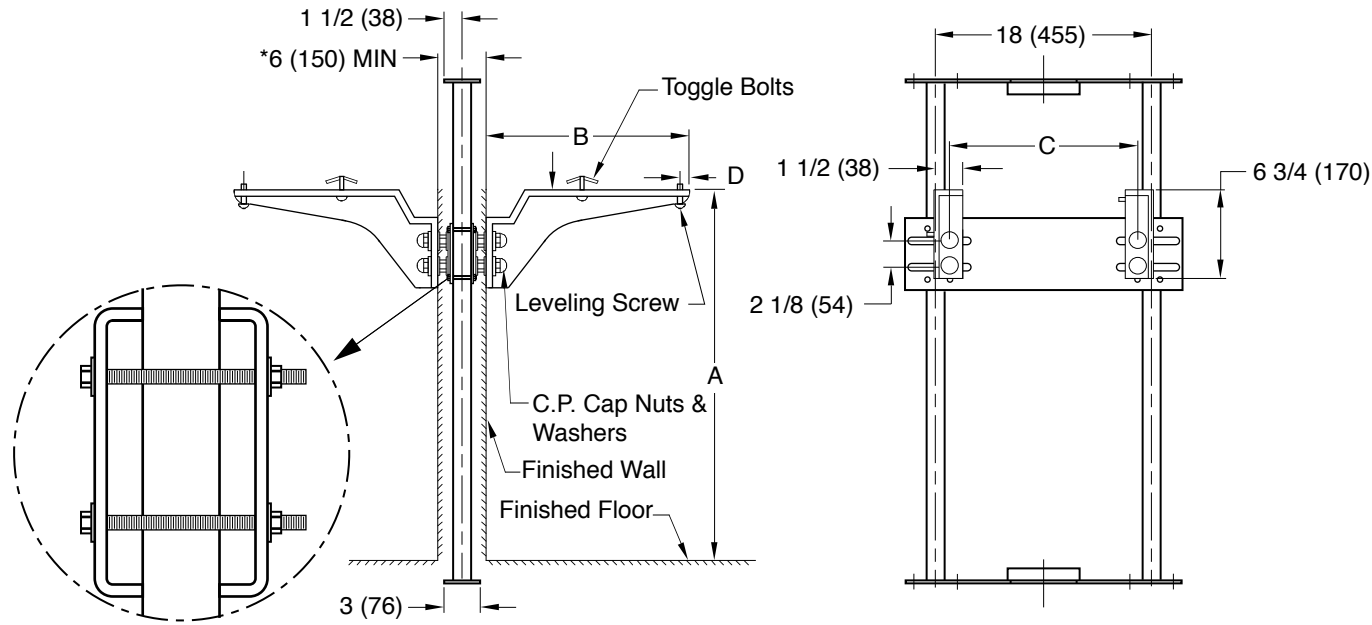
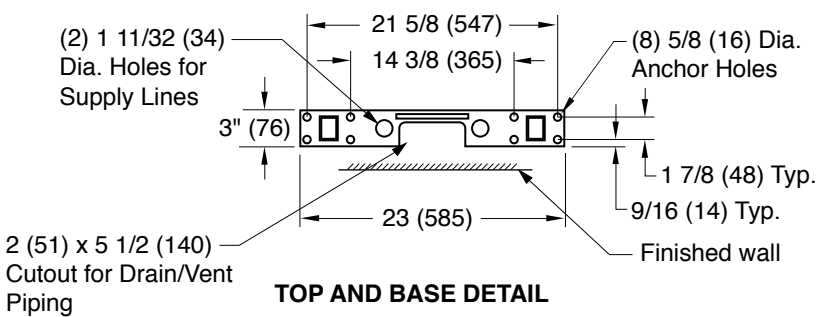

Fig. 0761D. . . . FOR BACK TO BACK SUPPORT

NOTE: The rough-in dimensions listed on this drawing are based on current information available to Jay R. Smith by the fixture manufacturers. We recommend that you verify these dimensions with the fixture manufacturer. We will not accept responsibility for rough-in dimension changes by the fixture manufacturer.

NOTE: *This dimension can be increased when required (Specify wall thickness).

NOTE: Dimensions shown in parenthesis are in millimeters.



ROUGH-IN TABLE

FIXTURE MFG.	NAME	NUMBER	SIZE	A	B	C	D

DRAWING NUMBER: S0761D
 SIZE: A
 SCALE: NONE
 DATE: 07/22/02
 APPROVED BY: AM
 CHECKED BY: CR
 DRAWN BY: JJ
 FIGURE NUMBER: 0761D
 DIMENSIONS ARE SUBJECT TO MANUFACTURERS TOLERANCE AND CHANGE WITHOUT NOTICE
 WE CAN ASSUME NO RESPONSIBILITY FOR USE OF SUPERSEDED OR VOID DATA

D	9-27-10	Added ® to LABOR SAVER & logo	RN	CL	WEIGHT POUNDS	VOLUME CUBIC FEET	FIGURE NUMBER
C	12/09/02	Revised per George Flegel	JJ	AM			0761D
B	08/05/02	Added Solid Lines on Arms	JJ	AM			
A	07/31/02	Revised View	JJ	AM			
REV.	DATE	DESCRIPTION	BY	CKD. BY			