

J

SMITH® JAY R. SMITH MFG. CO.®
 MEMBER OF MORRIS GROUP INTERNATIONAL
 POST OFFICE BOX 3237
 MONTGOMERY, ALABAMA 36109-0237 (USA)
 TEL: 334-277-8520 FAX: 334-272-7396 www.jrsmith.com



LOCATION

LAVATORY SUPPORTS WITH CONCEALED ARMS

WALL MOUNTED

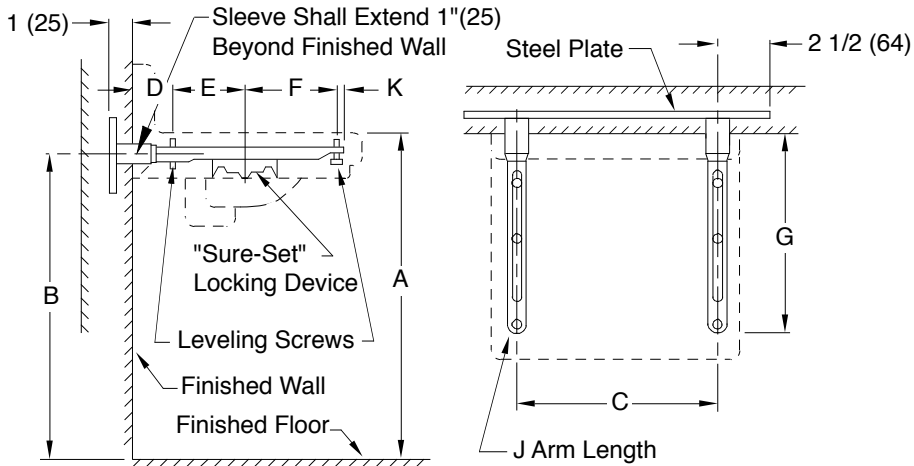

Fig. 0722 . . . FOR HIGH BACK LAVATORIES SET ON STEEL PLATE SECURED IN WALL

ROUGHING-IN TABLE

FIXTURE MFG.	NAME	NUMBER	SIZE	A	B	C	D	E	F	G	J	K
AM. STD.	LUCERNE	0350.132	20 (510) x 18 (455)	31 (785)	29 1/4 (745)	16 3/4 (425)	4 (100)	6 (150)	6 (150)	16 1/2 (420)	19 (485)	1/2 (13)
AM. STD.	LUCERNE	0350.603	24 (610) x 20 (510)	31 (785)	29 1/4 (745)	20 1/4 (515)	4 (100)	7 (180)	7 (180)	18 1/2 (370)	20 (510)	1/2 (13)
AM. STD.	LUCERNE	0351.072	20 (510) x 18 (455)	31 (785)	29 1/4 (745)	16 3/4 (425)	4 (100)	6 (150)	6 (150)	16 1/2 (420)	19 (485)	1/2 (13)
AM. STD.	LUCERNE	0351.247	24 (610) x 20 (510)	31 (785)	29 1/4 (745)	20 1/4 (515)	4 (100)	7 (180)	7 (180)	18 1/2 (420)	20 (510)	1/2 (13)
CRANE	NORWICH	1-194	20 (510) x 18 (455)	31 (785)	29 3/8 (746)	16 1/4 (415)	4 (100)	5 5/8 (143)	4 3/8 (111)	14 1/2 (370)	16 (405)	1/2 (13)
CRANE	NORWICH	1-194	24 (610) x 21 (535)	31 (785)	29 3/8 (746)	19 1/2 (495)	4 (100)	5 5/8 (143)	7 1/8 (181)	17 1/4 (440)	19 (485)	1/2 (13)
ELJER	DELWYN	051-1634, 1838	18 (455) x 15 (380)	31 (785)	29 1/4 (745)	15 1/2 (395)	3 (76)	5 (125)	4 3/4 (120)	13 1/2 (345)	17M (430)	3/4 (19)
ELJER	SIGNATURE	051-2101, 4, 8	20 (510) x 18 (455)	34 (865)	32 (815)	17 (430)	4 (100)	5 5/8 (143)	5 5/8 (143)	15 3/4 (400)	18M (455)	1/2 (13)
KOHLER	GREENWICH	K-2030, 1, 2, 4, 6	20 (510) x 18 (455)	31 (785)	29 (735)	17 1/4 (440)	3 1/4 (83)	5 1/4 (135)	5 1/4 (135)	14 1/4 (440)	16 (405)	1/2 (13)
KOHLER	GREENWICH	K-2030, 1, 2, 4, 6	24 (610) x 20 (510)	31 (785)	29 (735)	19 (485)	3 1/4 (83)	5 3/4 (145)	6 1/4 (160)	16 3/4 (425)	19 (485)	1 1/2 (38)
U. RUNDLE	NEW CAMDEN	4648, 9	20 (510) x 18 (455)	31 (785)	29 3/8 (746)	16 1/4 (415)	4 1/2 (115)	2 1/2 (64)	4 (100)	13 1/2 (345)	16 (405)	2 1/2 (64)

NOTE: The rough-in dimensions listed on this drawing are based on current information available to Jay R. Smith by the fixture manufacturers. We recommend that you verify these dimensions with the fixture manufacturer. We will not accept responsibility for rough-in dimension changes by the fixture manufacturer.

NOTE: Dimensions shown in parentheses are in millimeters.

DRAWING NUMBER
S0722

SIZE
A

SCALE:
NONE

DATE:
1-26-73

APPROVED BY:

CHECKED BY:
RP

DRAWN BY:
BDS

0722

WE CAN ASSUME NO RESPONSIBILITY FOR USE OF SUPERSEDED OR VOID DATA

DIMENSIONS ARE SUBJECT TO MANUFACTURERS TOLERANCE AND CHANGE WITHOUT NOTICE

J H	03/07/02 4-2-97	Revised Roughing-in Table Added Millimeters	JJ EMB	CL BS	WEIGHT POUNDS	VOLUME CUBIC FEET	FIGURE NUMBER 0722
REV.	DATE	DESCRIPTION	BY	CKD. BY			

D

SMITH® JAY R. SMITH MFG. CO.®
 MEMBER OF MORRIS GROUP INTERNATIONAL
 POST OFFICE BOX 3237
 MONTGOMERY, ALABAMA 36109-0237 (USA)
 TEL: 334-277-8520 FAX: 334-272-7396 www.jrsmith.com



LOCATION

LAVATORY SUPPORTS WITH CONCEALED ARMS

WALL MOUNTED

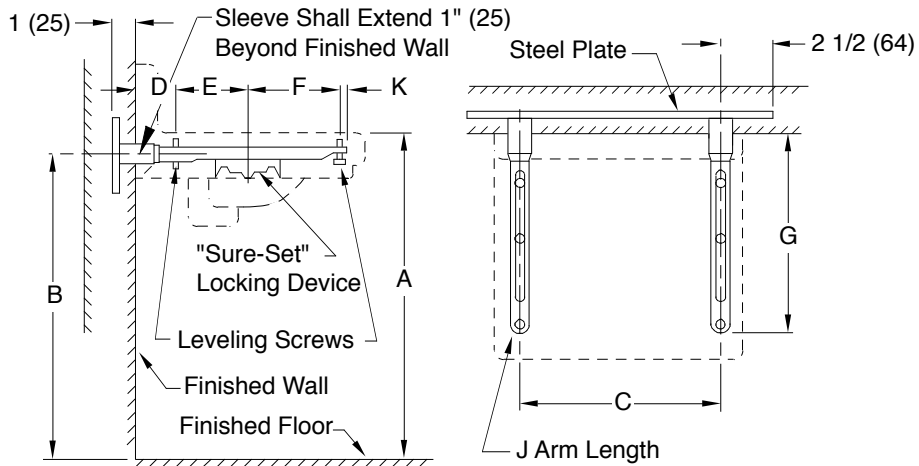

Fig. 0722 . . . FOR HIGH BACK LAVATORIES SET ON STEEL PLATE SECURED IN WALL

ROUGHING-IN TABLE

FIXTURE NAME				NUMBER			SIZE	
A	B	C	D	E	F	G	J	K

NOTE: The rough-in dimensions listed on this drawing are based on current information available to Jay R. Smith by the fixture manufacturers. We recommend that you verify these dimensions with the fixture manufacturer. We will not accept responsibility for rough-in dimension changes by the fixture manufacturer.

NOTE: Dimensions shown in parentheses are in millimeters.

DRAWING NUMBER
S0722 (B)

SIZE
A

SCALE:
NONE

DATE:
10-9-69

APPROVED BY:

CHECKED BY:
BH

DRAWN BY:
RVB

0722

WE CAN ASSUME NO RESPONSIBILITY FOR USE OF SUPERSEDED OR VOID DATA

DIMENSIONS ARE SUBJECT TO MANUFACTURERS TOLERANCE AND CHANGE WITHOUT NOTICE

D	4-2-97	Added Millimeters	EMB	BS
C	6-22-94	Revised	EMB	BS
B	8-10-93	Submittal Update	EMB	BS
REV.	DATE	DESCRIPTION	BY	CKD. BY

WEIGHT POUNDS	VOLUME CUBIC FEET	FIGURE NUMBER 0722
------------------	----------------------	------------------------------