

LABOR SAVER® LAVATORY SUPPORTS WITH CONCEALED ARMS FOR NARROW WALL INSTALLATION

FLOOR MOUNTED TYPE

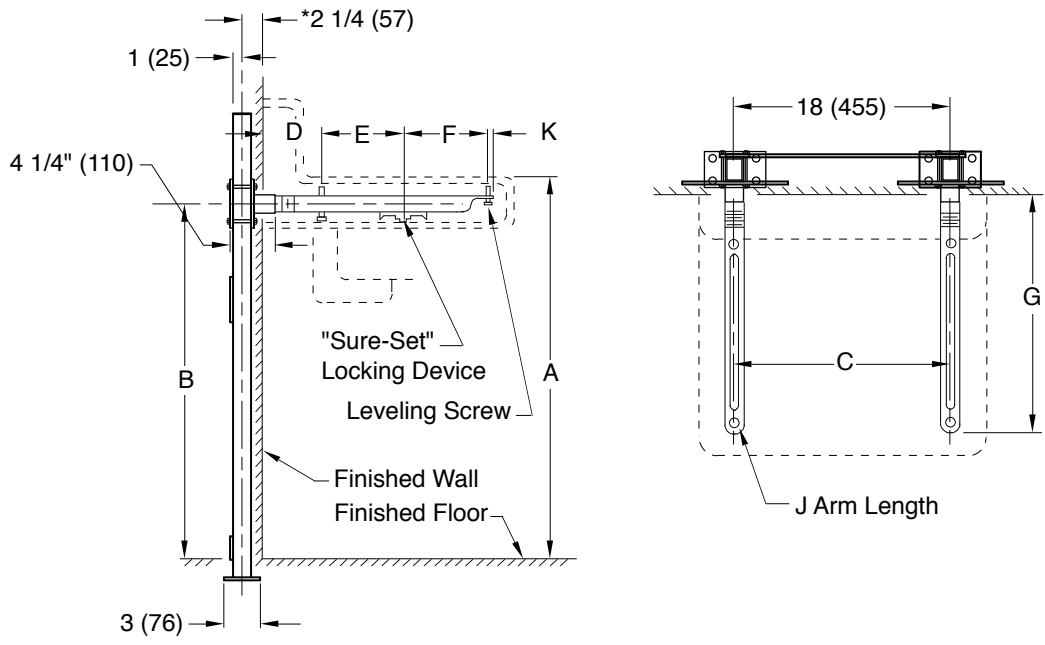

Fig. 0710-Z . . . FOR HIGH BACK LAVATORIES (shown)

NOTE: The rough-in dimensions listed on this drawing are based on current information available to Jay R. Smith by the fixture manufacturers. We recommend that you verify these dimensions with the fixture manufacturer. We will not accept responsibility for rough-in dimension changes by the fixture manufacturer.

NOTE: Modified Arms Required. Modify Arms per Attached dwg.

NOTE: *This dimension includes a wall thickness of 1/2". For greater wall thickness, specify centerline of upright to finished wall dimension.

NOTE: Dimensions shown in parentheses are in millimeters.

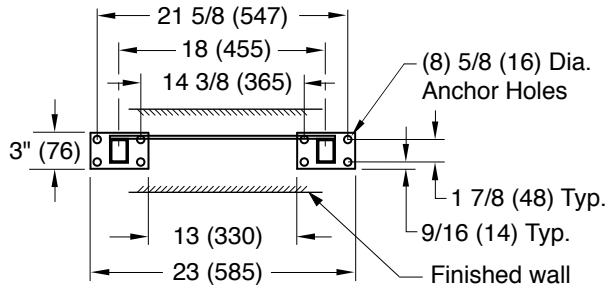

BASE DETAIL

ROUGH-IN TABLE

FIXTURE MFG.		NAME		NUMBER		SIZE			
A	B	C	D	E	F	G	J	K	

DRAWING NUMBER: S0710 (-Z)
 SIZE: A
 SCALE: NONE
 DATE: 12/29/00
 APPROVED BY: AM
 CHECKED BY: CR
 DRAWN BY: JJ
0710 (-Z)
 DIMENSIONS ARE SUBJECT TO MANUFACTURERS TOLERANCE AND CHANGE WITHOUT NOTICE
 WE CAN ASSUME NO RESPONSIBILITY FOR USE OF SUPERSEDED OR VOID DATA

REV.	DATE	DESCRIPTION	BY	CKD. BY	WEIGHT POUNDS	VOLUME CUBIC FEET	FIGURE NUMBER 0710 (-Z)