

M



JAY R. SMITH MFG. CO.
 MEMBER OF MORRIS GROUP INTERNATIONAL
 POST OFFICE BOX 3237
 MONTGOMERY, ALABAMA 36109-0237 (USA)
 TEL: 334-277-8520 FAX: 334-272-7396 www.jrsmith.com



MEMBER OF:

LOCATION

URINAL SUPPORTS FOR OFF-THE-FLOOR URINALS

WITH SUPPORTING AND BEARING STUDS FOR BLOWOUT AND WASHOUT URINALS

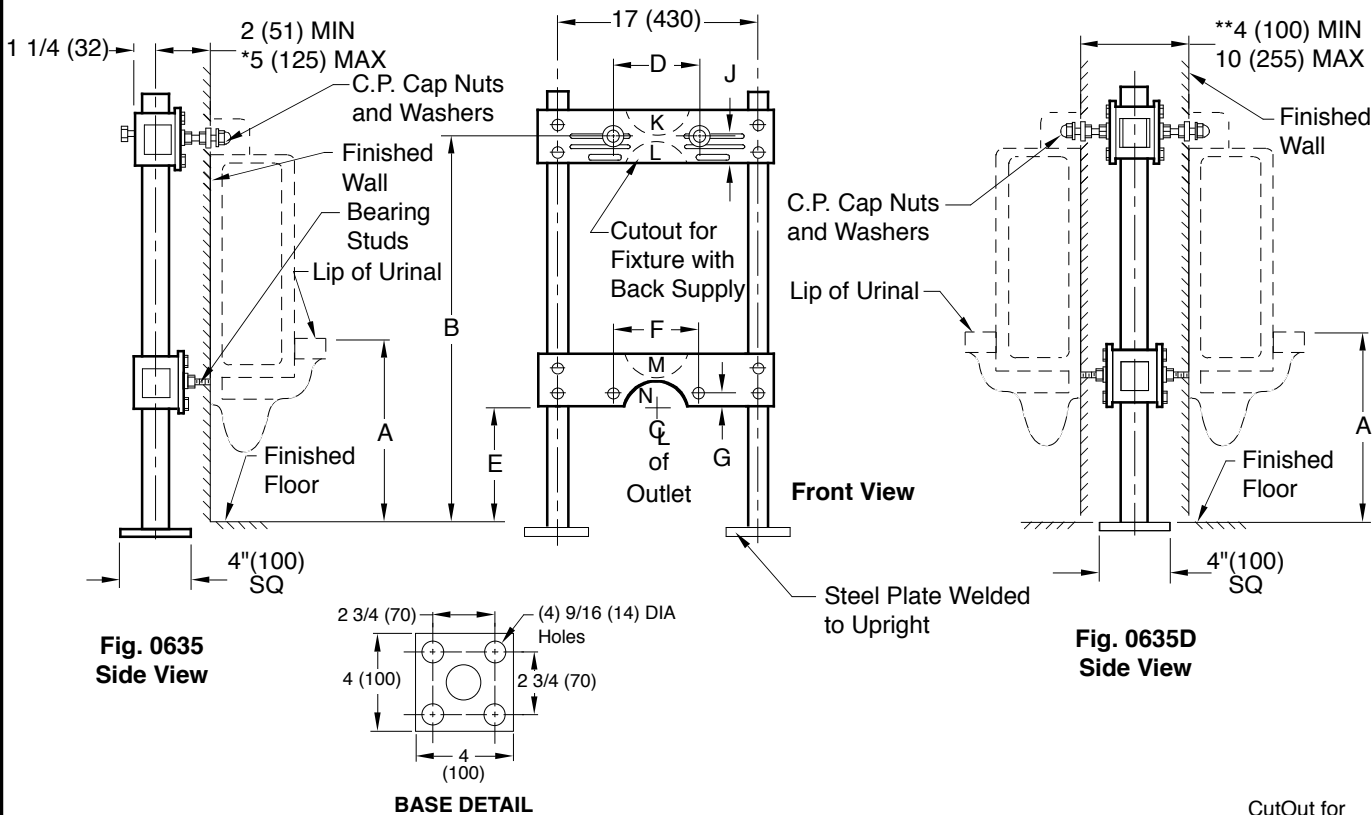

Fig. 0635
Side View

Fig. 0635D
Side View

BASE DETAIL

ROUGH-IN TABLE

FIXTURE MFG.	NAME	NUMBER	A	B	D	E	F	G	J	CutOut for			
										(Inlet)	(Outlet)		
Am. Std.	Allbrook	6545.016	24 (610)	36 1/8 (918)	5 (125)	16 1/2 (420)	5 (125)	1 (25)	2 (51)	-	X	-	X
Briggs	Rushton	B-6940, 1	24 (610)	28 (710)	7 (180)	17 (430)	7 (180)	2 (51)	3 (76)	X	-	X	-
Case	Casco	2325, 6	22 (560)	42 (1065)	6 (150)	18 5/8 (473)	5 (125)	1 (25)	1 (25)	-	X	-	X
Crane	Expedio	7-101, 3	22 (560)	26 1/2 (675)	5 (125)	15 1/2 (395)	7 (180)	3 (76)	3 1/2 (89)	X	-	X	-
Crane	Expedio	7-104	22 (560)	26 1/2 (675)	7 (180)	15 1/2 (395)	7 (180)	3 (76)	2 (51)	-	-	X	-
Crane	Manhattan	7-105, 8	22 (560)	34 1/4 (870)	5 (125)	15 1/2 (395)	4 (100)	2 (51)	2 (51)	-	-	-	X
Crane	Santo	7-111, 2	22 (560)	34 1/4 (870)	5 (125)	17 1/2 (445)	4 (100)	2 (51)	2 (51)	-	-	-	X
U. Rundle	Colby	4981	22 (560)	33 1/4 (845)	5 1/4 (135)	14 1/2 (370)	5 (125)	1/2 (13)	2 (51)	-	-	-	X
U. Rundle	Celtic	4989, 92	22 (560)	42 1/2 (1080)	7 (180)	19 (485)	7 (180)	1 (25)	1 (25)	-	X	-	X
U. Rundle	Colburn	4990	22 (560)	33 1/2 (850)	4 1/2 (115)	17 (430)	4 1/2 (115)	2 (51)	2 (51)	-	-	-	-
U. Rundle	Challenge	4993, 4	22 (560)	42 3/4 (1085)	7 (180)	20 (510)	7 (180)	1 (25)	1 (25)	-	X	-	X

NOTE: All support bases must be securely anchored to a rigid floor and/or other rigid substructure with (4) 1/2" bolts furnished by others.

NOTE: *This dimension can be increased when fixture support is to be installed behind the wall (specify when required and wall thickness).

**This dimension can be increased when required (specify wall thickness).

NOTE: Dimensions shown in parentheses are in millimeters.

REV.	DATE	DESCRIPTION	BY	CKD. BY
M	2-24-12	Rev. Dim., Base Plate	TBW	TWK
L	01/20/11	Updated Logo	JJ	TW
K	04/22/09	Added Note	JJ	AM
J	01/11/00	Revised Base Plate	JJ	BS

WEIGHT POUNDS	VOLUME CUBIC FEET	FIGURE NUMBER
		0635



WARNING: Cancer and Reproductive Harm - www.P65Warnings.ca.gov

DRAWING NUMBER
S0635SIZE
ASCALE:
NONEDATE:
2-8-73

APPROVED BY:

CHECKED BY:
RPDRAWN BY:
JH

0635

FIGURE NUMBER

WE CAN ASSUME NO RESPONSIBILITY FOR USE OF SUPERSEDED OR VOID DATA

DIMENSIONS ARE SUBJECT TO MANUFACTURERS TOLERANCE AND CHANGE WITHOUT NOTICE