

M



**JAY R. SMITH MFG. CO.®**  
 MEMBER OF MORRIS GROUP INTERNATIONAL  
 POST OFFICE BOX 3237  
 MONTGOMERY, ALABAMA 36109-0237 (USA)  
 TEL: 334-277-8520 FAX: 334-272-7396 www.jrsmith.com



MEMBER OF:

LOCATION

DRAWING NUMBER  
S0634SIZE  
ASCALE:  
NONEDATE:  
1-23-73

APPROVED BY:

CHECKED BY:  
RPDRAWN BY:  
JH

0634

FIGURE  
NUMBER

WE CAN ASSUME NO RESPONSIBILITY FOR USE OF SUPERSEDED OR VOID DATA

DIMENSIONS ARE SUBJECT TO MANUFACTURERS TOLERANCE AND CHANGE WITHOUT NOTICE

# URINAL SUPPORTS FOR OFF-THE-FLOOR URINALS

## WITH SUPPORTING STUDS FOR BLOWOUT AND WASHOUT URINALS

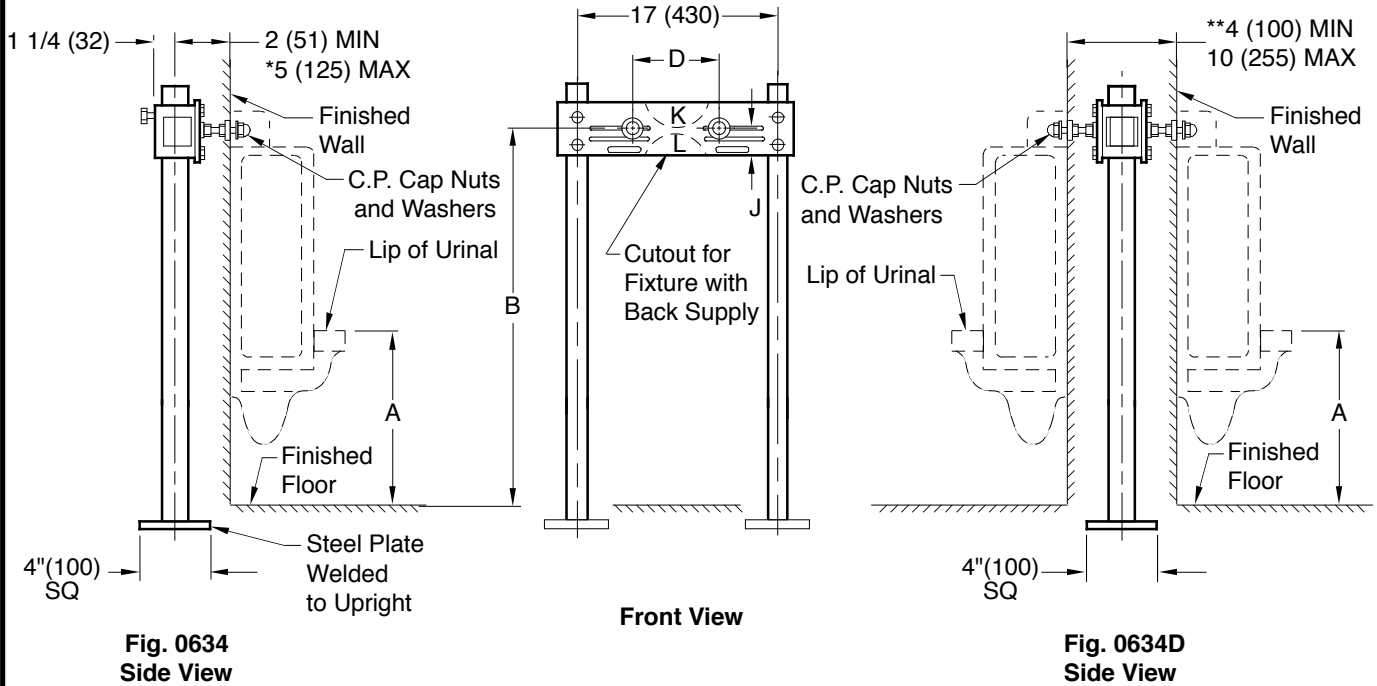

**Fig. 0634**  
Side View

**Front View**

**Fig. 0634D**  
Side View

### ROUGH-IN TABLE

FIXTURE MFG.	NAME	NUMBER	A	B	D	J	Cutout for (Inlet)	
							K	L
Am. Std.	Allbrook	6545.016	24 (610)	36 1/8 (918)	5 (125)	2 (51)	-	X
Briggs	Rushton	B-6940, 1	24 (610)	28 (710)	7 (180)	3 (76)	X	-
Case	Casco	2325, 6	22 (560)	42 (1065)	6 (150)	1 (25)	-	X
Crane	Expedio	7-101, 3	22 (560)	26 1/2 (675)	5 (125)	3 1/2 (89)	X	-
Crane	Expedio	7-104	22 (560)	26 1/2 (675)	7 (180)	2 (51)	-	-
Crane	Manhattan	7-105, 8	22 (560)	34 1/4 (870)	5 (125)	2 (51)	-	-
Crane	Santo	7-111, 2	22 (560)	34 1/4 (870)	5 (125)	2 (51)	-	-
U. Rundle	Colby	4981	22 (560)	33 1/4 (845)	5 1/2 (140)	2 (51)	-	-
U. Rundle	Celtic	4989, 92	22 (560)	42 1/2 (1080)	7 (180)	1 (25)	-	X
U. Rundle	Colburn	4990	22 (560)	33 1/2 (850)	4 1/4 (110)	2 (51)	-	-
U. Rundle	Challenge	4993, 4	22 (560)	42 3/4 (1085)	7 (180)	1 (25)	-	X

**NOTE:** All support bases must be securely anchored to a rigid floor and/or other rigid substructure with (4) 1/2" bolts furnished by others.

**NOTE:** \*This dimension can be increased when fixture support is to be installed behind the wall (specify when required and wall thickness).

\*\*This dimension can be increased when required (specify wall thickness).

**NOTE:** Dimensions shown in parentheses are in millimeters.

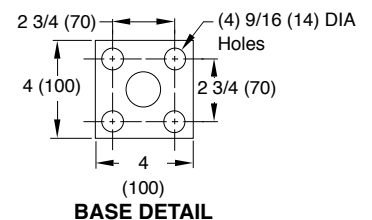

**BASE DETAIL**

M	2-24-12	Rev. Dim., Base Plate	TBW	TWK	WEIGHT	VOLUME	FIGURE NUMBER
L	01/20/11	Updated Logo	JJ	TW	POUNDS	CUBIC FEET	<b>0634</b>
K	04/22/09	Added Note	JJ	AM			
J	01/11/00	Revised Base Plate	JJ	BS			
REV.	DATE	DESCRIPTION	BY	CKD. BY			



**WARNING:** Cancer and Reproductive Harm - www.P65Warnings.ca.gov