

COMPACT FIXTURE SUPPORTS WITHOUT WASTE FITTINGS FOR SIPHON JET WATER CLOSETS

STUD-MOUNT FRAME

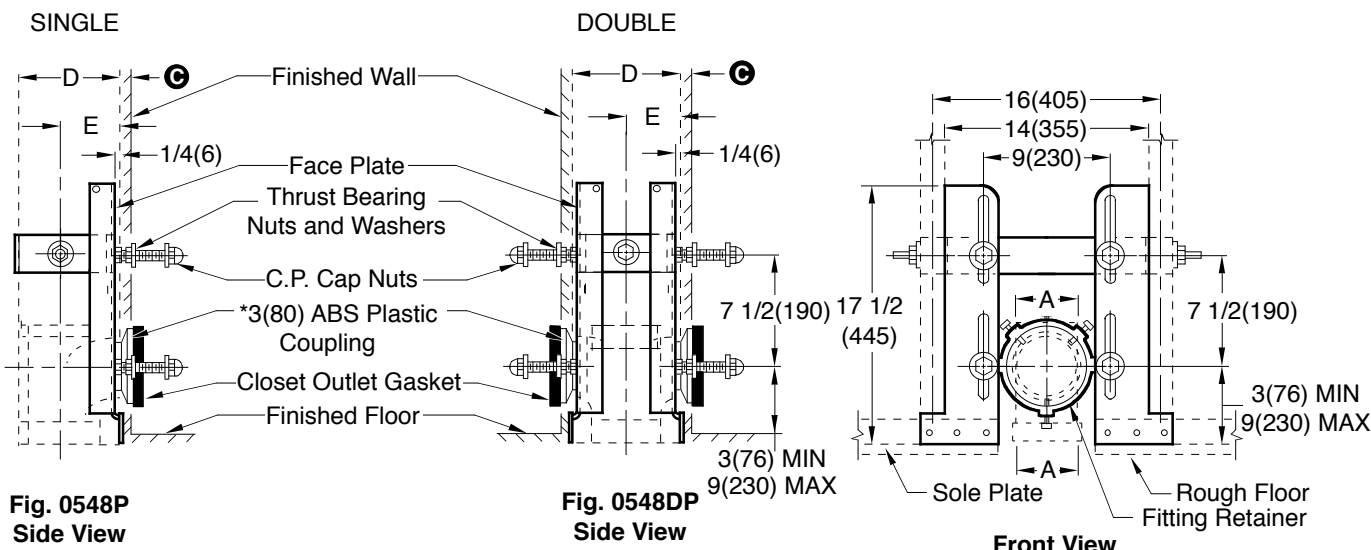

Fig. 0548P
Side View

Fig. 0548DP
Side View

Front View

Fig. 0548P . . . 3"(75) Plastic Connection
 Fig. 0548DP . . . 3"(75) Plastic Connection

Fig.	A SIZE	D STUD	E
0548P	3(75)	2 x 8	3 3/4(95)
0548DP	3(75)	2 x 10	4 3/4(120)

- NOTES:**
- Coupling should extend 5/16"(8) beyond finished wall.
 - Double support for use with gravity flush tank type water closets only.
 - ⊙ 1/2"(13) MIN to 1 1/4"(32) MAX as furnished.

INSTALLATION INSTRUCTIONS

- Center stack between two studs back "E" dimension (shown in table) from stud faces. 0548DP must be centered in sole plate.
- Cut out hole in sole plate and floor for stack.
- To determine the height of the stack in relation to the finished floor, find specific closet outlet c/L to be used, then measure down from centerline of closet outlet 2 15/16"(75) for 3"(75) size and 3 15/16"(100) for 4"(100) size.
- Make up stack connection.
- Attach plastic fitting adaptor and reinforcing strap to the back of the face plates by means of the fixture studs, then place assembly against plastic fitting and lock in place with set screws.
- Face plate should now be nailed to sole plate.
- The two vertical studs are set into place then drilled for permanently anchoring the reinforcing strap by means of the stud bolts, nuts and washers.
- Insert the coupling into the fitting and adjust it to extend 5/16"(8) beyond finished wall, then solvent weld into place.
- Assemble the bearing nuts and washers to the fixture supporting studs. The fixture studs should extend 2 1/4"(51) beyond finished wall.
- Adjust the bearing nuts so that washers extend 1/16"(2) beyond finished wall.
- After wall is erected, remove any plaster grout touching the fixture studs, bearing nuts, washers and coupling.
- Place gasket in closet recess and set closet on studs protruding from wall making sure closet outlet is centered on coupling.
- Place fiber washers on studs. Apply the two bottom and top left cap nuts, tighten securely. Apply the top right cap nut hand tight and snug up 1/4 turn with wrench.

NOTE: Dimensions shown in parentheses are in millimeters.

DRAWING NUMBER S0548P
 SIZE A
 SCALE: NONE
 DATE: 1-17-86
 APPROVED BY: SB
 CHECKED BY: JD
 DRAWN BY: CM
0548P, 0548DP
 DIMENSIONS ARE SUBJECT TO MANUFACTURERS TOLERANCE AND CHANGE WITHOUT NOTICE

REV.	DATE	DESCRIPTION	BY	CKD. BY	WEIGHT POUNDS	VOLUME CUBIC FEET	FIGURE NUMBER
	11-19-13 4-10-13 1-27-06 8-26-05 6-17-99	Revised Dimensions, Notes Remove Notes Revised Note & Removed Note Revised Note Removed Note	TBW TBW RN TBW CMD	CL CL CL CL BS			0548P, 0548DP