

ADJUSTABLE FIXTURE SUPPORTS FOR SIPHON JET WATER CLOSETS

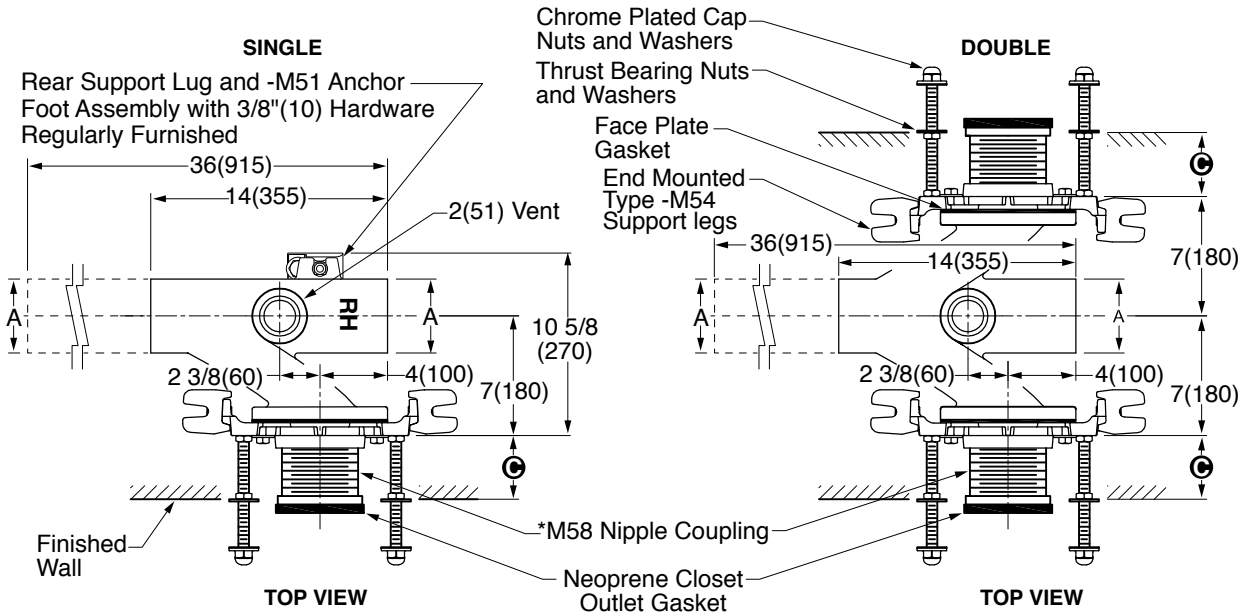

NOTES:

1. Base Support must be securely anchored to the floor (with one 1/2" (13) bolt per base support provided by installer.)
2. All single supports shall have the rear support lug anchored with 1/2" (13) bolt by contractor to assure a rigid installation. The rear support completes the 3 point anchoring system for ultimate stability of the installation.
3. Dimensions shown in parentheses are in millimeters.
4. **Dimension to top of vent.

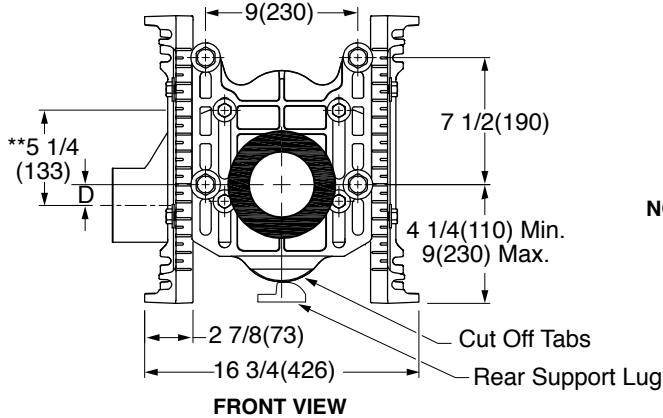

A SIZE	D	
	MIN	MAX
4(100)	5/8(16)	3 3/8(87)

NOTE: Cast Iron Components are Duco Coated.

*LENGTH	MIN	MAX
10(255)	8 3/4"(222)	9 3/4"(247)

*NOTE: When nipple lengths between 3 1/4"(83) and 9 3/4"(247) are specified, the 10"(255) nipple will be supplied. The threaded end of nipple must be cut to specified length by others.

- Fig. 0211LY (-M58-M54) NO-HUB Left Hand
- Fig. 0211RY (-M58-M54) NO-HUB Right Hand
- Fig. 0211DY (-M58-M54) NO-HUB Double
- Fig. 0221LY (-M58-M54) NO-HUB Left Hand Long Barrel
- Fig. 0221RY (-M58-M54) NO-HUB Right Hand Long Barrel
- Fig. 0221DY (-M58-M54) NO-HUB Double Long Barrel

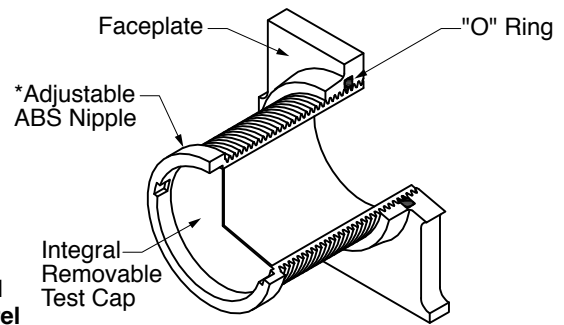

*ABS (Regularly Furnished)

DRAWING NUMBER: s0211Y, 0221Y (-M58-M54)
 SIZE: A
 SCALE: NONE
 DATE: 4-4-12
 APPROVED BY: JM
 CHECKED BY: AM
 DRAWN BY: CR
 DIMENSIONS ARE SUBJECT TO MANUFACTURERS TOLERANCE AND CHANGE WITHOUT NOTICE

REV.	DATE	DESCRIPTION	BY	CKD. BY	WEIGHT POUNDS	VOLUME CUBIC FEET	FIGURE NUMBER
G	7-6-17	Added Note	TBW	JM			0211Y (-M58-M54) 0221Y (-M58-M54)
F	9-21-15	Rev. Callout, Note	TBW	CL			
E	10-27-14	Added 0221Y (-M58-M54)	TBW	CL			
D	8-5-13	Rev. Note, Callouts	TBW	JM			